

TABLE OF CONTENTS

General Information and Operation

	PAGE
About This Manual	2
Warranty	3
For Your Protection	3
Introduction	4
License and Regulation Information	5
Installation Instructions	6
Basic Operating Procedures	7
External Features and Controls	10
Use of Controls	12
Specifications	16

Basic Technical Service

Introduction	18
Figures 1 - 12	19-29
Zeroing the S-Meter	30
Tube Trouble Locator	31
Receiver Failure Chart	32
Transmitter Failure Chart	33
Fuses	34
Lamps	34

Troubleshooting and Alignment

General Information	35
Test Equipment	35
Power Supplies	35
Synthesizer Board	36
RECEIVER - General Information	40
S-Meter Calibrate	40
AGC	40
Squelch	40
Manual Tuning Calibrate	41
27MHz RF Amplifier	42
455KHz IF	43
6MHZ IF	43
Noise Blanker	44
Noise Limiter	45
Receiver Audio	45
TRANSMITTER - General Information	46
Power Metering	46
RF Drive, Final and Neutralization	47
Balanced Modulator Board	47
AM Transmit Audio	49
Compression Adjustment	49
Sideband Transmit Audio	49
ALC Adjustment	50
Returning the Set for Service	50
Parts List	51
Technician's Information Form	68

ABOUT THIS MANUAL

We at Tram realize that technical manuals can be dull. Most folks dislike reading manuals and we can't blame them. We hope this manual will be different.

We have tried to present all the dope on your new D201 in a clear and easy-to-understand fashion. Everything from installing your antenna to aligning your IF is covered. And even if you don't know a mho from an ohm this manual will be of great value to you in learning your way around your new D201.

The first section is for everyone: we suggest some precautions, we fill you in on how we test the radio before you ever see it and we tell you how to install it at your home 20. All those controls? Not only do we explain what they do, but we explain how to best use them.

The second section covers easy maintenance that any owner can take a crack at, maybe saving a few dollars in the process. Tired tubes, problems in Receive and problems in Transmit, all are investigated and quick fixes are suggested.

The third section is for the electronics whiz only. Fancy test equipment and Government licenses are required to do most everything in here. Anyone curious about the inner workings of his set though, will find circuit descriptions and explanations in this section.

The parts list is last. All those resistors and capacitors, diodes and transistors have a number and value and should you need a replacement part, we try to help you get it down the street instead of sending clear across the country to us.

A full schematic is tucked in the back. While it may look like a road map of Los Angeles to most folks, the service technician will find everything he needs to know about gain measurements, signal injection values, point voltages and signal flow right there on the schematic.

That's about it. Find a comfortable chair, sit awhile and get familiar with this manual and with your great new radio.

LIMITED WARRANTY

TRAM/DIAMOND CORPORATION, hereinafter referred to as TRAM, warrants that, for a period of six (6) months (90 days for vacuum tubes) from the date of first sale to original retail purchaser, this TRAM product will be free of defect in materials and workmanship. TRAM's obligation is limited to repairing or replacing, parts or equipment which are returned, transportation and insurance pre-paid, without alteration or further damage, and which in TRAM's judgment, were originally defective or became defective in normal use.

For specifics concerning Warranty procedures and shipping instructions see page 50.

CAUTION

Before applying power to your new D201, lift the top cover and check that the following components have not shaken loose in shipping: See Figure 3 for component locations.

1. Check all tubes and make sure they are firmly seated in their sockets.
2. Check the Balanced Modulator Board to make sure it is fully seated.
3. Check the Synthesizer Board to make sure both cables are properly connected and main terminal plug fully inserted.
4. Check the Auxiliary Audio Board to insure it is seated firmly on its connector.
5. Check the Receiver Auxiliary Board to insure it is seated firmly in its connector.

FOR YOUR PROTECTION

1. Fill out your Warranty Card and **mail it**.
2. Record the Serial Number of your new D201 and keep this information in a safe place. (This number is stamped in the lower left corner of the chassis next to the speaker.)
3. If your radio is stolen, notify the Police and the Factory **immediately**.
NOTE: Serial Numbers of all radios returned to the factory for service are recorded. Radios whose serial numbers have been altered or eradicated will not be serviced.
4. Do not discard original shipping carton and packing materials.

INTRODUCTION

Your new D201 is a highly sophisticated, carefully tested electronic instrument. Aside from the usual alignment and bench testing, each D201 is subjected to a physical shock test while being monitored under receive and full load transmit conditions. In addition, each D201 must successfully pass a minimum 40 hour dynamic cycle test sequence consisting of one hour "ON" (while alternately switching between Receive and full power Transmit) and 1/2 hour "OFF". The electronic monitoring systems used during these tests are capable of detecting even momentary malfunctions.

Before attempting to use the radio you should become familiar with the **Installation** and **Operation** sections of this manual. You will find instructions to the effect that an owner should make only recommended adjustments. This is most important. Certain adjustments can **only** be made by a qualified electronic technician using well-calibrated test equipment.

Transmitter circuit adjustments can only be performed by technicians having FCC First or Second Class Commercial Operator licenses. An owner will degrade the performance of his set and may even render it inoperative if he disturbs factory settings. Sets returned to the factory that show evidence of unauthorized adjustment or circuit revision cannot be serviced under the Warranty if such servicing would tend to jeopardize our FCC type acceptances.

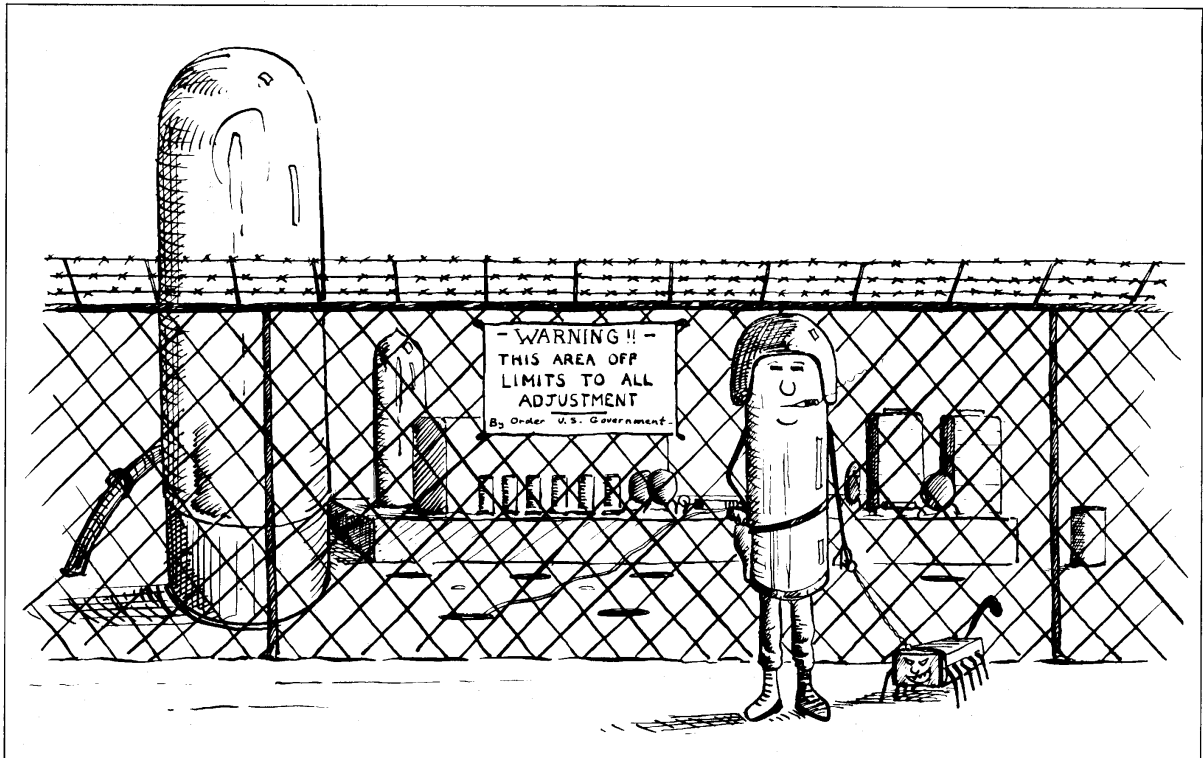

LICENSE AND REGULATION INFORMATION

excerpted from sub-Part #95 of FCC Rules and Regulations

The Federal Communications Commission has made it possible for anyone over the age of 18 years to obtain a license to operate two-way radios in the Citizen's Band. It is a violation of federal law to operate this equipment without a license.

To obtain your license; first, become familiar with the rules and regulations governing the use of Class D Citizen's Band Radio by reading sub-Part #95 of FCC Rules and Regulations.

Second, fill out FCC application form #505, enclosed in this manual. Sign the form and mail it with the prescribed Application Fee to FCC, Gettysburg, PA 17325. The FCC will issue you your license and assign station identification numbers to your equipment.

Provisions have been made by the FCC for temporary, sixty day, operation of Class D Citizen's Band equipment. Temporary permit, FCC form #555-B, is designed to serve as an interim license provided a permanent license has been applied for by the filing and **mailing** of FCC form #505. Temporary form #555-B must be filled out in full and kept in a safe place. It is valid for 60 days only and may not be renewed.

Keep your license close to your equipment at all times. Fill out a transmitter identification card, FCC form #452 and attach it to the radio. Do not transmit unless you have your license. Make transmissions short and to the point and listen to the channel before transmitting to be sure it is not in use.

Operating and equipment requirements are covered in Part #95 of the Federal Communications Commission's Rules and Regulations. Note the proper use of **Channel 9** (27.065 MHz). This channel has been reserved for communications concerned with the **immediate safety of life** of individuals, the **immediate protection of property or assistance to a motorist**. For this reason, Channel 9 is uniquely marked on both the D201 dials. All use of this equipment must conform to FCC requirements. **TYPE ACCEPTANCE DATA IS ON FILE WITH THE FCC, LISTED AS FCC TYPE NUMBER "D201"**.

INSTALLATION INSTRUCTIONS

ANTENNAS & LEAD-IN CABLE

A quarter-wave vertical ground plane type antenna is suitable for base station use. Improved results will be obtained with commercially available 5/8 wave vertical antennas that have matching sections to match 50 ohm coaxial cable. For directional coverage to greater distances, a vertical beam antenna is recommended. In areas where there is a lot of activity, a beam antenna, because of its directional characteristics, will reduce interference from other stations not directly in the path of the beam's directivity.

CAUTION: Antennas and feedlines should **never** be installed near power lines as it is **extremely dangerous**.

In all cases, install the antenna in the open, away from surrounding objects. Care should be taken in using an ungrounded type of antenna since static charges collected along the antenna elements can damage the metering systems and first RF Amplifier, as well as generate annoying noise in the receiver. A lightning arrester installed in the transmission line affords protection from static discharge damage.

Most commercially available antennas are designed for use with 50 ohm coaxial cable. Be sure to use the correct impedance as specified by the antenna manufacturer. The D201 Pi-network output will match a 50 ohm system, but will not correct for a mismatch between the antenna and cable feeding it. The D201 power meter can be used to read SWR on your antenna system and is useful in correcting mismatch. (Refer to BASIC OPERATING PROCEDURES)

For feedline lengths under 50 feet, RG-58A/U for 50 ohm systems will be satisfactory. For less loss or longer runs, RG-8A/U is recommended.

Exercise **extreme** care when attaching coaxial fittings to the cable. Be sure that the center conductor is soldered. Remember that a cold soldered joint will result in a loss of power. Solder the braid carefully. Screw the fitting firmly on the antenna. Where the fitting is exposed to the weather, wrap it with vinyl tape. **The use of a lightning arrester is recommended.** Most antenna difficulties result from lack of care in above assembly procedures.

GROUNDING

For safety, it is recommended that a ground wire (#14 or larger) or grounding braid be connected under a ground screw on the rear panel. (The 8-32 screw in the bottom cover, located below the antenna connector, is suggested for this purpose.) The other end of the ground wire should be connected to a cold water pipe (make sure it is grounded), a copper ground stake driven four or five feet into the earth, or the AC outlet box of a three wire polarized receptacle.

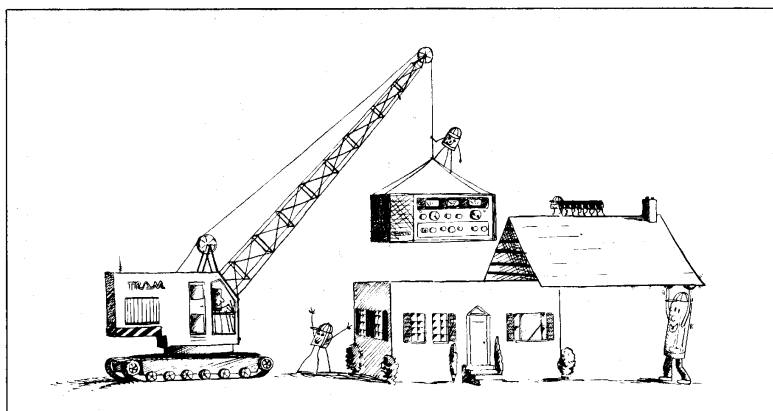

BASIC OPERATING PROCEDURES

CAUTION The D201 is a complex piece of electronic equipment; proper ventilation is essential. The louvers and venting are functional. Do not obstruct the free flow of air through the cabinet. Do not install the set in a closed space.

Remove the microphone from its box and connect it to the MIC JACK on the left side of the front panel. (See Figure 1) The D201 is equipped with a detachable line cord. Plug this cord into the recessed receptacle at the left rear of the chassis. (See Figure 2) Note that the D201 is completely inoperative whenever the top cover is raised. Connect antenna feedline to antenna connector on D201 rear panel.

For basic AM operation set the D201 controls as follows:

CONTROL	SETTING
1. MODE	AM
2. RF GAIN	Maximum CW (clockwise)
3. SQUELCH	Maximum CCW (counter clockwise)
4. CLARIFIER	12 o'clock (top center)
5. CRYSTAL-MANUAL	CRYSTAL
6. CRYSTAL SELECTOR	To desired channel
7. LIMITER	Click Off at maximum CCW
8. MIC GAIN	12 o'clock
9. TTC	3 o'clock
10. CAL	Push in for OFF
11. BLANKER	Push in for OFF
12. METER SWITCH	To S/PWR
13. VOL/PWR OFF	Turn ON and adjust for desired listening level.

The dials and S-meter will light up when the power is on. Wait a few moments for the set to warm up and you will hear background noise or signals if the channel is active. Locate an inactive channel and press the push-to-talk bar on the microphone. The MOD LIGHT will come on and the S-Meter will indicate carrier plus modulation as you speak. Release the bar to turn off the transmitter.

SWR CHECK:

When first connecting your new D201 it is recommended that the SWR of the antenna system in use be checked. SWR (standing wave ratio) is a measurement indicative of the overall match of the antenna system. Each of the elements in this system (the transmitter, the coax cable and the antenna) must be matched to one another for optimum performance. If a mis-match exists, standing waves develop along the transmission line indicating less than optimum operating conditions. An SWR of 2 to 1 is acceptable with optimum results gained as 1 to 1 is approached. The D201 transmitter should not be operated with an SWR of 4 to 1 or greater. To check the SWR proceed as follows:

1. Set MIC GAIN fully CCW and MODE to AM.
2. Set METER SWITCH to SWR CAL. Key the transmitter and adjust the SWR CAL CONTROL for full scale deflection ('CAL' at end of SWR scale).
3. Set METER SWITCH to SWR position and read SWR directly from SWR scale.
4. Return METER SWITCH and MIC GAIN control to customary positions.

If SWR is high the transmission line and antenna should be checked.

ANTENNA LOADING

For optimum performance the final amplifier circuits of the D201 should be tuned to the antenna system. To accomplish this proceed as follows:

Set Controls:

Power off/vol	ON
AM-LSB-USB	AM
Mic Gain	CCW
Meter Switch	S/PWR

1. Select a quiet midband channel and be sure it is not in use.
2. Key the transmitter by depressing the mic touch bar and sliding the locking collar up the shaft.
3. Observe the Power reading on the meter and alternately adjust the tune and load controls on the D201 Rear Panel until a peak reading is achieved on the meter.
4. Unkey the microphone.

Under normal conditions 1/4 turn of each adjustment should be adequate to match the final Amplifier to the antenna lead-in.

If more than 1/2 turn of either is required the antenna system should be checked for abnormally high SWR. This adjustment should be carried out quickly to minimize interference with other stations and once done insures the transmitter is efficiently matched to the antenna system in use.

For Sideband operation, set the D201 controls as follows:

CONTROL	SETTING
1. MODE	LSB or USB as desired
2. RF GAIN	Maximum CW
3. SQUELCH	Maximum CCW
4. CLARIFIER	12 o'clock (top center)
5. CRYSTAL MANUAL	Crystal
6. CRYSTAL SELECTOR	As desired (Ch. 16 frequently used for SB operation.)
7. LIMITER	Click off at Maximum CCW
8. MIC GAIN	12 o'clock
9. TTC	12 o'clock
10. CAL	Push in OFF
11. BLANKER	Push in OFF
12. METER SWITCH	To S/PWR
13. VOL/PWR OFF	Turn on and adjust volume for desired level.

Increasingly crowded conditions on the 27 MHz Citizen's Band, especially in urban areas, have resulted in greater use of the Sideband mode of transmission. A single sideband signal occupies one half the space of a conventional AM signal. Because of this each channel can handle twice the traffic in the sideband mode that would normally be possible in AM.

Single Sideband signals are distinguished from AM signals by the absence of carrier. When in an SSB mode, a received AM signal will usually be accompanied by a heterodyne (squeal). Since all AM transmissions contain both the upper and the lower sidebands, it is not unusual to hear AM stations perfectly when in either SSB mode. In the AM reception mode, a sideband signal will be unintelligible or highly distorted.

The easiest method of tuning single sideband signals is as follows:

1. Set mode switch to USB or LSB.
2. Set Channel select desired channel, CRYSTAL/MANUAL switch to CRYSTAL.
3. Slowly turn CLARIFIER to the left and right of center until a received signal becomes clear and easy to understand.
4. Slight adjustment of the clarifier may be necessary when listening to several sideband stations.

The manual tuning of single sideband signals is considerably more critical than tuning AM signals. The D201 is designed to tune as easily as possible; however, some care is required.

A recommended procedure for tuning sideband signals is as follows:

Having engaged the direct drive portion of the tuning mechanism, tune approximately one-half channel past the signal to be tuned. Turning the manual tune knob back toward the signal provides a 36:1 vernier tuning ratio. The signal can now be approached and carefully tuned using the vernier drive in about the middle of its range. The clarifier is not functional in the Manual Tune mode.

EXTERNAL FEATURES AND CONTROLS

FRONT PANEL

POWER OFF/VOL	Turns power on and off. Controls the receive volume.
RTC	Receive Tone Control. Varies pitch of receiver audio from bass to treble.
RF GAIN CONTROL	Reduces receiver front-end gain in order to increase strong-signal handling capability.
AM-LSB-USB SWITCH	Selects desired mode of operation for transmit and receive: AM, Lower Sideband, Upper Sideband.
SQUELCH	Provides a means of quieting the receiver from background noise or unwanted signals.
CRYSTAL/MANUAL SWITCH	Selects method of receive – Crystal controlled or Manually tuned.
MANUAL TUNING	Used to tune the receiver when the Crystal/Manual Switch is in the Manual position. Transmit frequency is controlled by the Crystal Selector regardless of Manual Tuning Dial position.
CAL	Calibrate. Functional in Manual Receiver only. Activated when pulled out. Provides a means of checking Manual Dial Accuracy.
CRYSTAL SELECTOR	Selects Transmit Channel at all times and the receive channel in the Crystal Receive mode. Selected channel is displayed in the window above the selector knob.
CLARIFIER	Shifts the transmitter and Crystal Receive frequencies above and below center channel frequency for SSB operation. NOT functional in the Manual Receiver Mode.
LIMITER, OFF	Activates the AM Noise Limiter and adjusts limiting action for varying levels of noise.
BLANKER	Activates Noise Blanker.
MIC GAIN	Controls the sensitivity of the Microphone Amplifier. Normally set at 12 o'clock.
TTC	Transmitter Tone Control. Controls the transmitter audio frequency response in a range from bass to treble. Normally set at 3 o'clock.
MIC	Microphone Jack. Mating plug is attached to the microphone cord supplied.
MOD LIGHT	AM: When transmitting, light glows dimly with carrier and flashes in proportion to modulation. In Receive, light flashes in proportion to speaker audio output. SSB: Light glows dimly during transmit. Flashes with speaker audio output in receive.
SSB LIGHT	Indicates SSB operation while in LSB or USB modes.
METER SWITCH	Selects meter function desired. S/Power Position: Meter will indicate incoming signal strength

in Receive and RF Power output in transmit. Switching is automatic.
 SWR CAL Position: See SWR CAL Control.
 SWR Position: Meter indicates SWR on the antenna cable after being calibrated.

SWR CAL CONTROL Used in conjunction with the Meter and the SWR switch to calibrate the SWR scale on the meter to the right-hand index.

PANEL METER S METER: Set meter switch to S/PWR position and read S units scale.
 POWER METER: Meter switch as above, read **watts** scale when transmitting.
 SWR: Read standing wave ratio on transmission line directly from SWR scale after Meter has been calibrated. (see page 7 for this procedure)

REAR PANEL

FUSE POST Contains Primary fuse. (use 3A slo-blo **only**)

AC CONNECTOR AC power cord connector.

T/R SWITCH (JACK) Jack for external or remote foot operated transmit/receive switch. (not supplied but available as an optional accessory)

TUNE RF Power Amp. tuning adjustment. C711

LOAD RF Power Amp. Loading adjustment. C712

ANT CONNECTOR SO-239. Mates with PL259 antenna connector and antenna lead-in wire.

EXT. SPEAKER (JACK) This jack was designed for an external or remote 4 ohm speaker. It is not suitable for the use of headphones with normal sensitivity because of hum pickup and sensitivity to switching transients.
 If headphone use is desired, it can be achieved by inserting a series resistor in the 1/4" phone plug supplied with the headphones or in a special adaptor that can be constructed from a 1/4" phone plug and a 1/4" jack. The proper resistor value will vary with headphone impedance and should be selected to provide a comfortable listening level with the VOL control at 12 o'clock. A resistor value of 3.3k ohms may be a suitable value.

TOP COVER

Hinged for easy access to replaceable internal components. Actuates AC interlock switch to remove power when cover is raised.

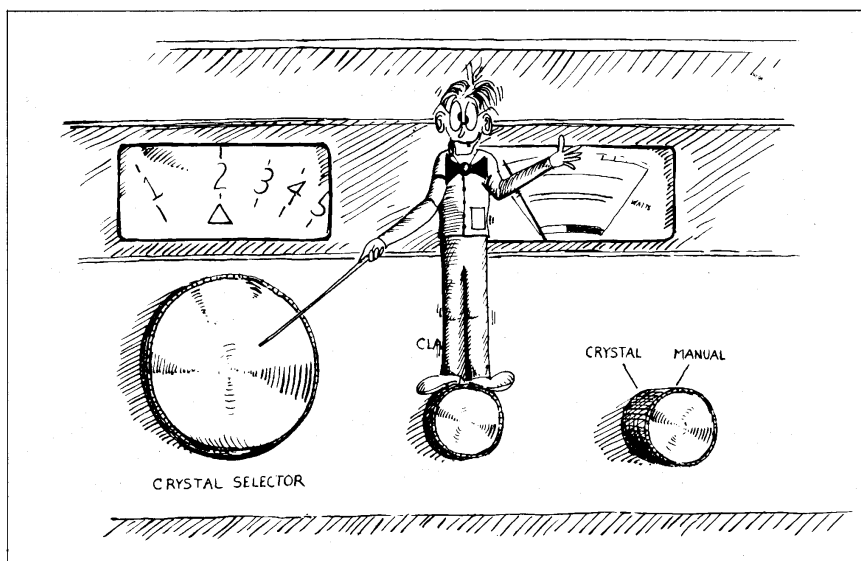

USE OF CONTROLS

RTC (Receiver Tone Control)

The receiver tone control allows the operator to adjust the receiver audio tone to suit his preference. This control allows adjustment over a range from bass to treble. Rotating the control CCW (counter clockwise) increases the bass tones. Turning the control CW (clockwise) decreases the bass tones, and, to some extent, the apparent audio level.

PWR OFF-VOL

The volume control is combined with the AC power switch. At the extreme CCW position of the knob, the AC power to the unit is switched off. Advancing the control CW turns on the power and increases the receiver audio volume.

RF GAIN

The RF gain control varies the gain of the RF amplifier. Maximum receiver sensitivity will be obtained with the control at extreme CW position; the **normal** position.

When copying strong signals under noisy or crowded conditions, it may be desirable to reduce the RF gain setting. To do this, set the volume control for nearly maximum and control the audio level with the RF GAIN.

NOTE: The S meter is calibrated with the RF GAIN fully CW; reducing the RF GAIN will result in a corresponding decrease in S meter readings.

AM-LSB-USB SWITCH

This switch selects the mode of operation for both Transmit and Receive portions of the radio. If, in the AM mode, the received signal sounds garbled and the S meter is fluctuating, it is probably an SSB signal. Try LSB or USB. In an SSB mode, it is possible to receive either AM or SSB signals; but mistuning of an AM signal, while in an SSB mode, will result in an annoying beat note.

SQUELCH

This control, when turned CW, quiets the receiver. If set just beyond the point where the receiver background noise disappears, any signal greater in strength than the noise level will restore the receiver to operation. The control may also be advanced so that only relatively strong signals will open the squelch. This can be particularly useful if the

band is open with skip signals that are weaker than the stations in your local area. The squelch can then be set to open only on the strong local signals.

CRYSTAL-MANUAL SWITCH

This switch allows the operator a choice of receive frequency control. In the CRYSTAL position, the D201 is a fully crystal controlled transceiver. The transmit and receive channels are selected by the 23-position CRYSTAL SELECTOR switch.

In the MANUAL position, there is independent selection of transmit and receive frequencies. The transmit frequency will always be crystal controlled on the channel indicated by the CRYSTAL SELECTOR dial. The receive frequency is governed by the MANUAL TUNING control and indicated on the MANUAL TUNING dial.

CAUTION If you have tuned a station in the Manual mode and you wish to transmit to it, you must set the CRYSTAL SELECTOR to the channel indicated on the Manual Tuning dial.

MANUAL TUNING

The D201 provides a two speed MANUAL TUNING control. Once the skill for operating this control has been achieved, it becomes extremely useful. The device is referred to as a dual ratio, reverse vernier ball drive and operates as follows:

Continuous rotation of the MANUAL TUNING knob in one direction engages the fast tune mechanism. A reversal in direction immediately picks up the vernier action and sustains it for almost a full turn of the knob before again engaging the fast tune in the new direction.

A recommended procedure for tuning is as follows:

Having engaged the direct drive portion of the tuning mechanism, tune approximately one-half channel past the signal to be tuned. Turning the MANUAL TUNE knob back toward the signal provides a 36:1 vernier tuning ratio. The signal can now be slowly approached and carefully tuned using the vernier drive in the middle of its range.

CAL SWITCH

This switch is provided to allow periodic checks of the accuracy of the receive MANUAL TUNING dial. It is useful in the MANUAL receive mode only and must be OFF (pushed in) at all times except when checking dial calibration. The proper calibration procedure is as follows. (Allow thirty minutes for the set to warm up before proceeding.)

1. Set CRYSTAL/MANUAL switch to MANUAL. Mode to AM.
2. Set the MANUAL TUNING dial to Channel 12.
3. Set the CRYSTAL SELECTOR to Channel 12.
4. Pull the CAL button out.
5. Rotate the MANUAL TUNING knob until zero beat is heard. Zero beat is obtained by turning the knob above Channel 12, then slowly turning back towards center. A loud beat note should be heard, decreasing in pitch as Channel 12 is approached. Continue rotating the knob in the same direction and a beat note increasing in pitch can be heard. Zero beat refers to the point of inaudibility between the two beat notes.
6. The dial is properly calibrated when zero beat occurs close to Channel 12.
7. Channels 9, 10 or 11 may be substituted for Channel 12 in Steps 2 through 6.
8. Return CAL button to the "IN" position.
9. If dial calibration is off, see manual tuning alignment instructions. (page 41)

CRYSTAL SELECTOR

The D201 is equipped for 23 channel operation. The desired channel is selected by

rotating the channel selector knob so that the number of the channel appears in the window. There is no stop on the switch so the knob can be continuously rotated in either direction allowing quick channel change.

With the CRYSTAL-MANUAL switch in the CRYSTAL position, the CRYSTAL SELECTOR determines both the transmit and receive channels. With the switch in the MANUAL position the channel selector determines just the transmit channel; the receive channel is determined by the MANUAL TUNE control.

CLARIFIER

This control allows the operator to make slight adjustments to the crystal receiver and transmitter output frequencies. It is useful as a "Fine Tune" control to adjust your frequency to that of other stations.

The CLARIFIER control is used mainly to tune in SSB signals while in the CRYSTAL receive mode. The control does not operate while in MANUAL receive. The fine tune function, when in MANUAL receive, is provided by the dual ratio, reverse vernier built into the receiver tuning mechanism.

If at any time you have difficulty properly tuning an SSB signal with the CLARIFIER control, try switching to MANUAL receive tuning. The other station may be off frequency and outside the range of the CLARIFIER control.

MIC GAIN

This control varies the gain of the microphone preamplifier. It does not significantly affect the modulation level under normal conditions of operation because the Compression-ALC will automatically compensate for widely varying sound levels.

In quiet locations the MIC GAIN can be turned up (CW). If the environment is very noisy, the MIC GAIN should be turned down (CCW). The operator should then hold the microphone about eight inches away and speak directly into it. This results in a clearer signal on the air without transmitting annoying background noises.

NOTE: If you have no transmitter output in SSB and no modulation in AM, check the MIC GAIN control to insure that it has not been turned all the way down.

TTC (Transmitter Tone Control)

The TRANSMITTER TONE CONTROL varies the frequency response of the microphone amplifier. As the control is rotated CW, the bass response is reduced and the treble is favored. This provides a means of tailoring the transmit audio to suit individual voice characteristics.

Short tests with the D201 and another station will enable the other operator to tell you which position of the TTC control best suits your voice.

LIMITER, OFF (Adjustable Noise Limiter)

The "LIMITER, OFF" control actuates the adjustable, series gate, noise limiting circuit. Rotating the control CW from the "OFF" position switches the Noise Limiter ON, and increases the limiting action. For low level or weak noise sources effective limiting will be achieved with small amounts of rotation from full CCW. As the strength of the noise source increases additional rotation CW will eliminate the noise signal. For extremely noisy conditions the LIMITER and BLANKER may be used simultaneously. Additional noise blanking results, but very strong adjacent channel signals may cause intermodulation in the receiver when both systems are employed.

The operator should experiment with these systems to determine the best method of noise elimination for particular conditions.

In the extreme CW position some distortion of the received AM signal will be heard. This is normal.

BLANKER

This switch actuates the RF impulse type noise blanker circuit. Pulling the switch out while listening to a signal will reduce the level of noise on the incoming signal. Noise blanking is accomplished by punching extremely short duration holes in the received signal coinciding with the accompanying noise impulse.

NOTE: These systems are designed to reduce impulse type noise such as auto ignitions and other sporadic, high level pulses. Noise limiting effectiveness decreases for very high repetition rates, or continuous noises, since they cannot be distinguished from a desired signal.

S/PWR, SWR METER

The D201 S meter is designed to indicate receive signal strength in S units and to automatically switch over to a calibrated RF Power meter when transmitting. In AM transmit, the RF Power Meter will read carrier power accurately in the absence of modulation. The meter reading will normally increase with modulation.

In SSB transmit modes, the RF Power meter will deflect from zero in proportion to modulation level. Because of human voice characteristics, the averaging power meter will tend to read below midscale as you are talking. A short, sharp whistle, which should be done for test purposes only, will cause the meter to read upscale and give a good indication of PEP output.

The meter also functions as an SWR meter when used in conjunction with the meter switch and SWR CAL Control. The switch should be in the S/PWR position except when checking the SWR. The SWR should be checked for each new antenna installation and periodically thereafter. SWR will change with weather conditions, so some variation from day to day is to be expected.

However, an abrupt change after a severe storm should be investigated. A gradually increasing SWR probably indicates deteriorating connections between antenna sections or at cable connections.

The D201 will operate satisfactorily with an SWR of 2 to 1 or less. If SWR readings greater than this are encountered, the antenna systems should be checked.

CAUTION: If the SWR is 4 to 1 or greater, do not continue transmitting.

TRAM/DIAMOND CORPORATION cannot certify compliance with FCC Regulations for an SWR of 4 to 1 or greater.

D201 SPECIFICATIONS

RECEIVER

SENSITIVITY: Channel 1 through 23	SSB-better than 0.1uv for 10db (S+N)/N, carrier ON/OFF. AM-Better than 0.35uv for 10db (S+N)/N.
Above Channel 23	SSB-better than 0.25uv for 10db (S+N)/N, carrier ON/OFF. AM-better than 0.75uv for 10db (S+N)/N.
GAIN: Channel 1 through 23	RF input signals at rated sensitivity provide greater than 1 watt of audio output.
Above Channel 23	AM-less than 1.5uv for 1 watt of audio output. SSB-less than 0.5uv for 1 watt of audio output.
SELECTIVITY:	SSB-6db at 2.1 KHz. AM-6db at 6.0 KHz.
AGC:	Less than 16db audio output change from 1uv to 100,000uv, fast attack, slow release for SSB.
AUDIO FREQUENCY RESPONSE:	Adjustable receive tone control (RTC) greater than 20db change below 400 Hz.
SQUELCH:	Adjustable, threshold from below rated sensitivity to over 5000uv.
AUDIO DISTORTION:	Less than 2% with 1 KHz sine wave into 4 ohms at a 1 watt level.
AUDIO MAX. OUTPUT:	4 watts at 10% T.H.D. into 4 ohms.
IMAGE REJECTION:	Better than 80db above rated sensitivity.
IF REJECTION:	Better than 80db above rated sensitivity.
IF FREQUENCY:	SSB-6.255 MHz. AM-6.2565 MHz, 455 KHz.
ADJACENT CHANNEL REJECTION:	Greater than 80db.
DESENSITIZATION:	Better than 80db for -3db desensitization of desired signal.
RF INTERMODULATION DISTORTION:	Better than 75db.
CRYSTAL CLARIFIER RANGE:	± 800 Hz (1600 Hz total) typical.
MANUAL TUNING:	2-speed reverse-vernier ball drive. Fast, 120 KHz per knob rotation; vernier, 20 KHz per knob rotation.
FREQUENCY STABILITY:	After 30 minutes warm-up; crystal, less than 5 Hz per 15 minutes. Manual, less than 100 Hz per 15 minutes.
NOISE REDUCTION:	RF Noise Blanker and Adjustable Level Series Gate Limiter. Each is switchable.

TRANSMITTER

SSB POWER:	25 watts PEP input. 12 watts PEP output (FCC limit).
AM POWER:	4 watts output. (FCC limit).
MODULATION LEVEL:	Adjustable, 0 to 100% modulation.
MODULATION FREQUENCY RESPONSE:	TTC adjustable, bass to treble.
SSB ALC:	70db range.
AM COMPRESSION:	70db range.
HARMONIC SUPPRESSION AND SPURIOUS EMISSIONS:	Better than FCC requirement.
ANTENNA MATCHING:	Adjustable, will match antenna loads of 25 to 100 ohms.
SSB CARRIER SUPPRESSION:	Better than -40db.
SSB OPPOSITE SIDEBAND SUPPRESSION:	Better than -60db at 1 KHz.
CARRIER FREQUENCY TOLERANCE:	\pm 100 Hz nominal.
CLARIFIER RANGE:	\pm 800 Hz (1600 Hz total) typical.
GENERAL	
SUPPLY VOLTAGE:	117 VAC nominal @ 50/60 Hz.
POWER CONSUMPTION:	Less than 200 watts.
OVERALL SIZE:	21 1/2" W, 7 1/4" H, 13" D.
SHIPPING WEIGHT:	36 pounds.
MICROPHONE:	Supplied, Astatic GD104, HI-Z crystal.

TECHNICAL SERVICE

Introduction

We hope you never need to use the following portion of this manual. But in case you do, we have tried to lay out the technical service section and schematic as clearly and logically as possible. We want to be sure using the manual isn't more complicated than fixing the set.

The first section of Technical Service deals with problems involving tubes, pilot lamps, S-Meter adjustment and fuses. In addition, SYMPTOM/CAUSE charts are provided to help identify specific problems and suggest solutions.

The second section covers advanced troubleshooting and alignment procedures. A First or Second Class F.C.C. License, sophisticated test equipment and considerable technical experience are required to perform the procedures outlined. If you're not lucky enough to possess all of these stay clear of this section. Usually, more problems are created by well-meaning troubleshooters than are remedied. Problems whose scope goes beyond the material included here should receive factory attention. Failures related to the Balanced modulator Board and Synthesizer Board in particular should be serviced by the factory. The removable nature of these boards is designed to facilitate this.

Remember, modifications void the Warranty. Good luck and good hunting.

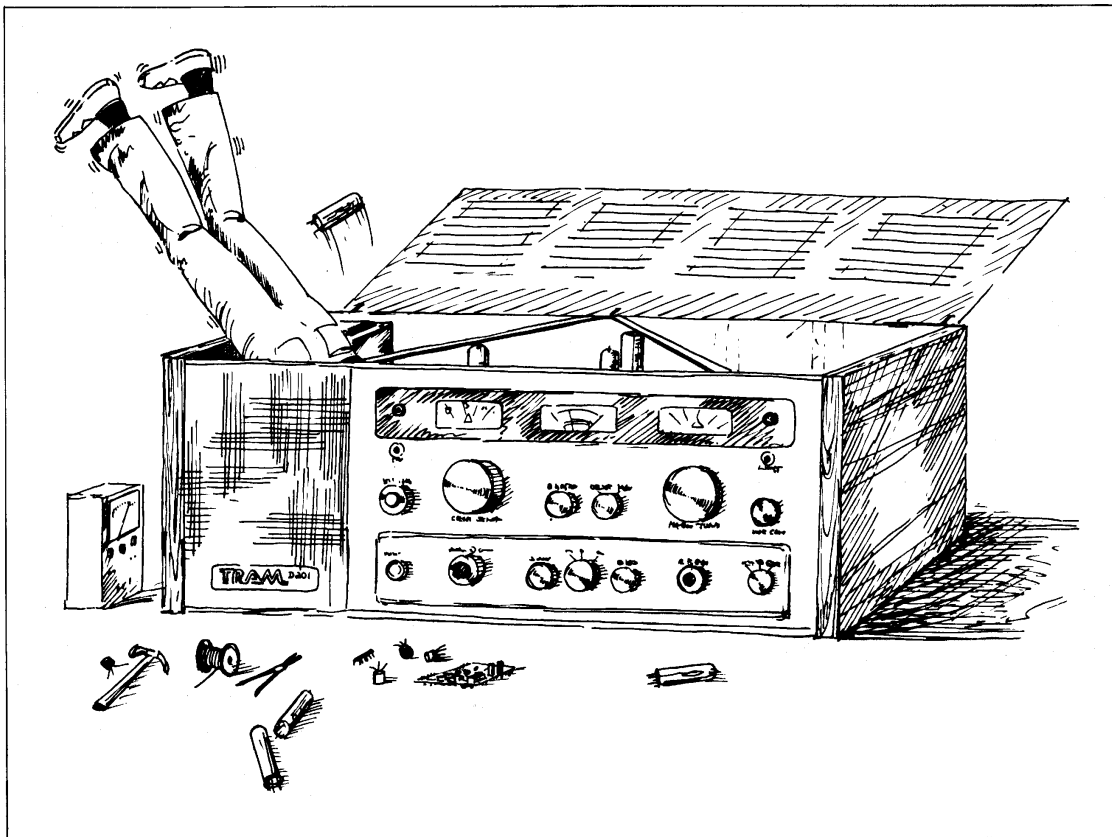

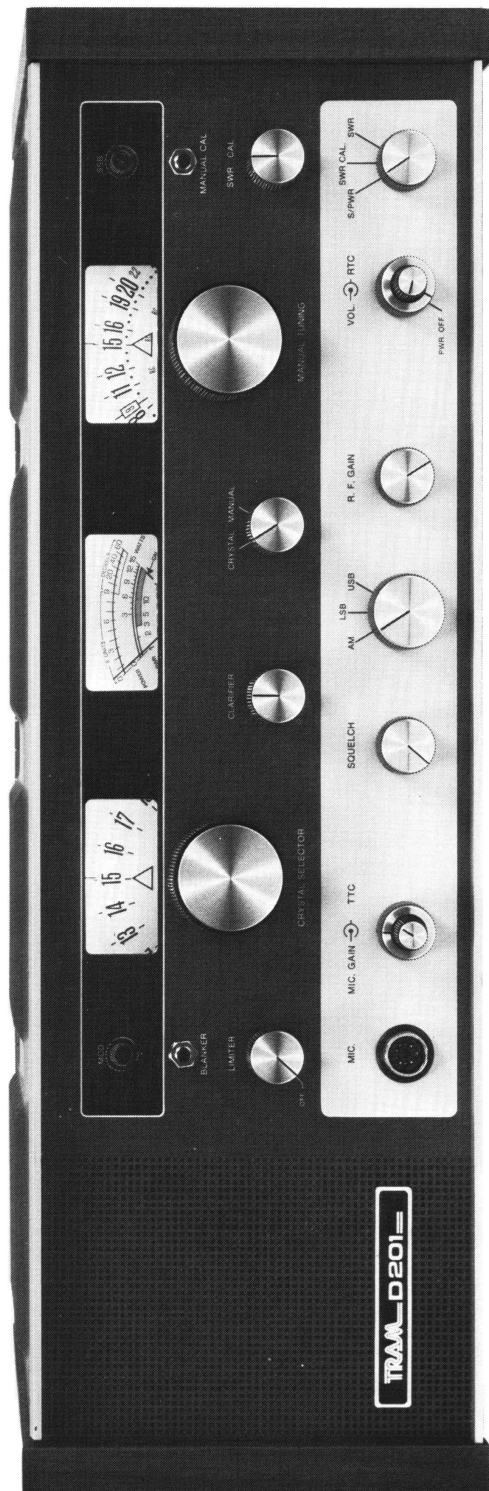

Fig. 1

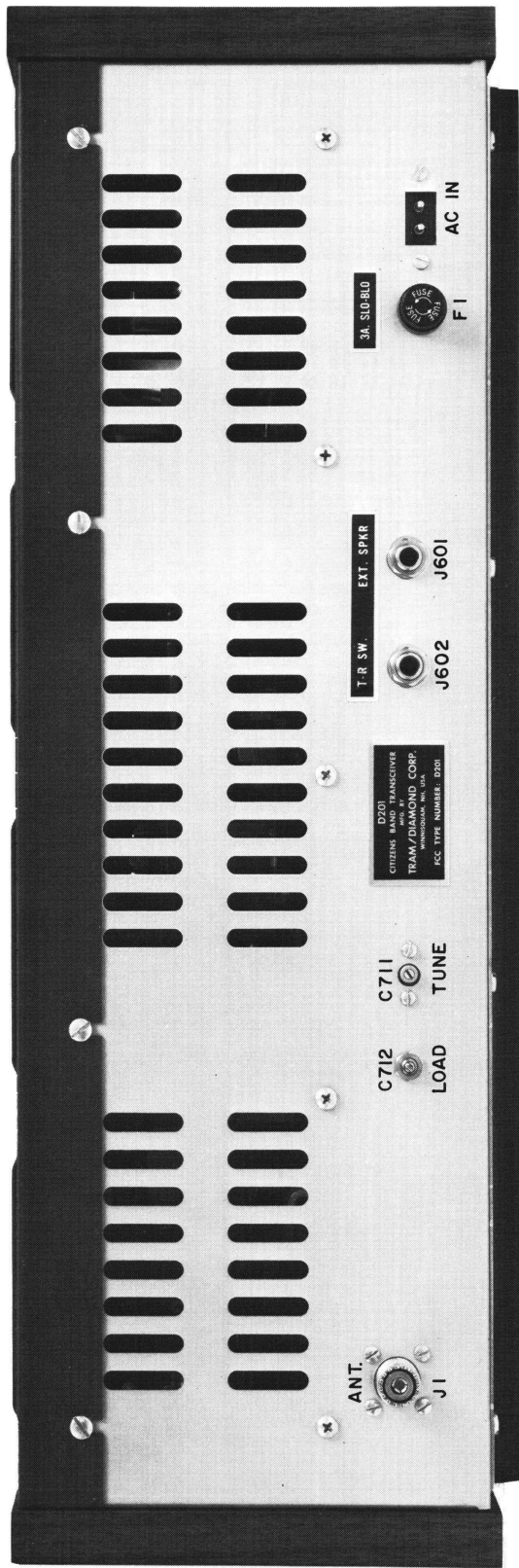
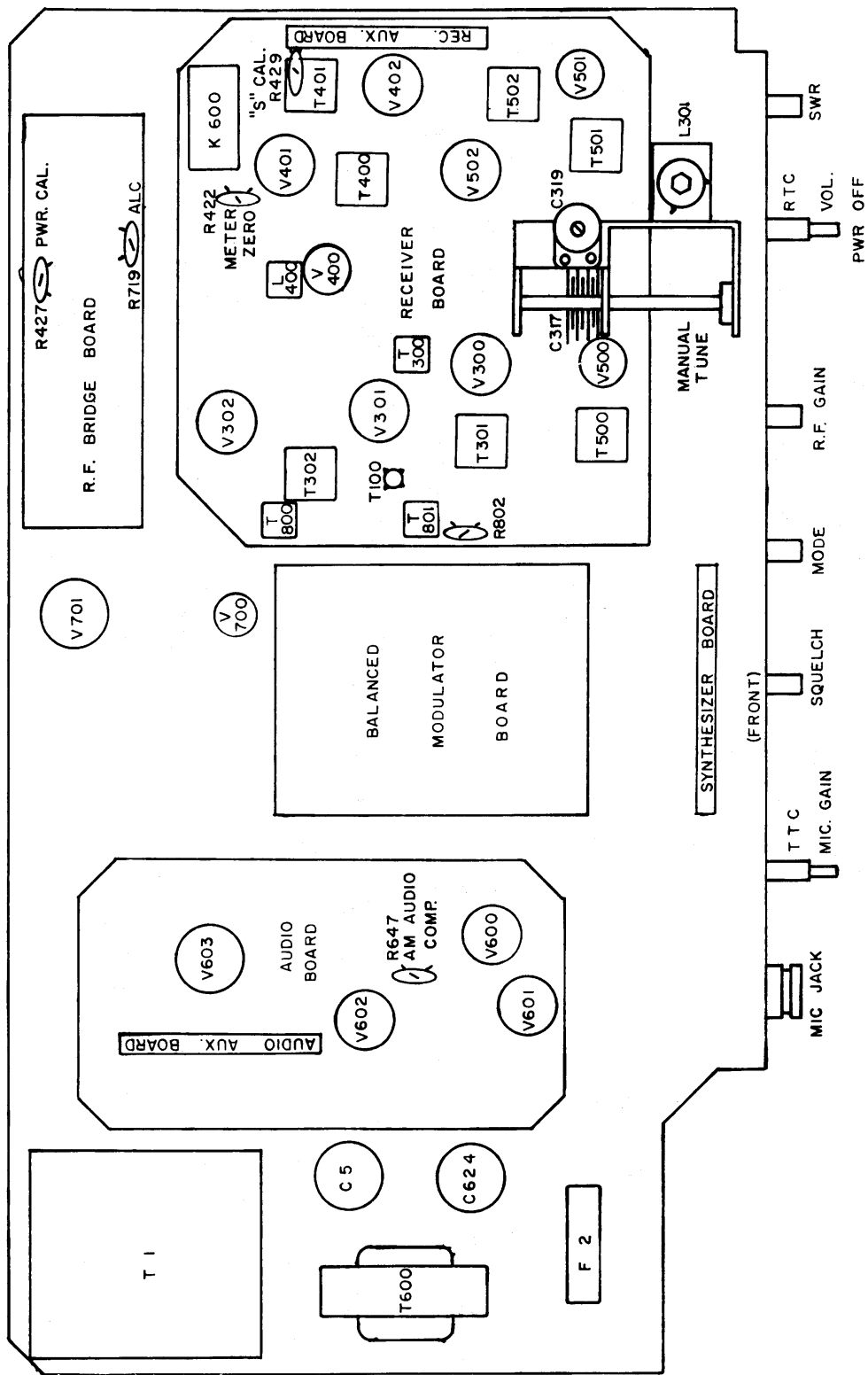
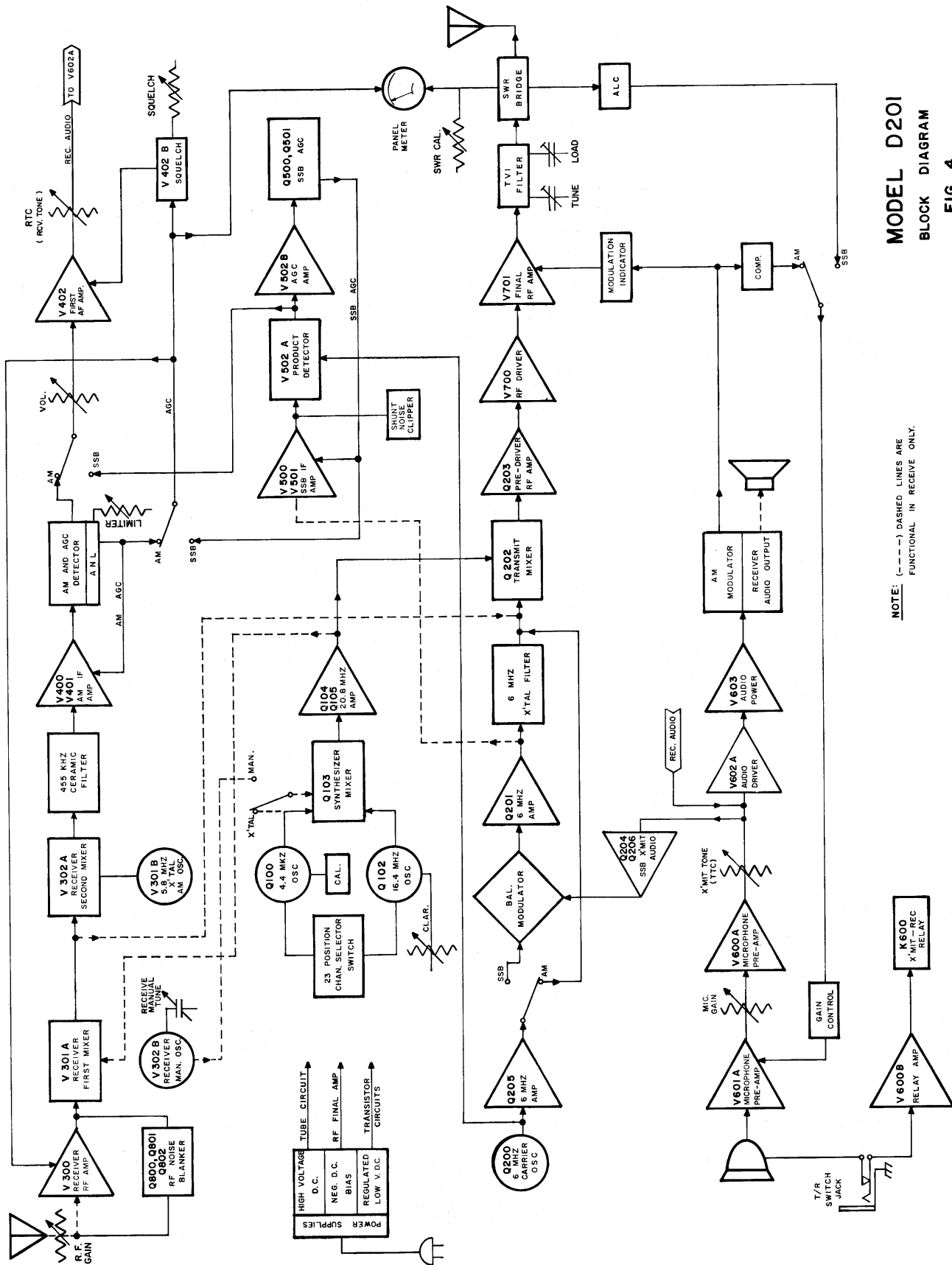

Fig. 2



D201 TOP CHASSIS VIEW
Fig. 3



MODEL D201
BLOCK DIAGRAM
FIG. 4

NOTE: (---) DASHED LINES ARE FUNCTIONAL IN RECEIVE ONLY.

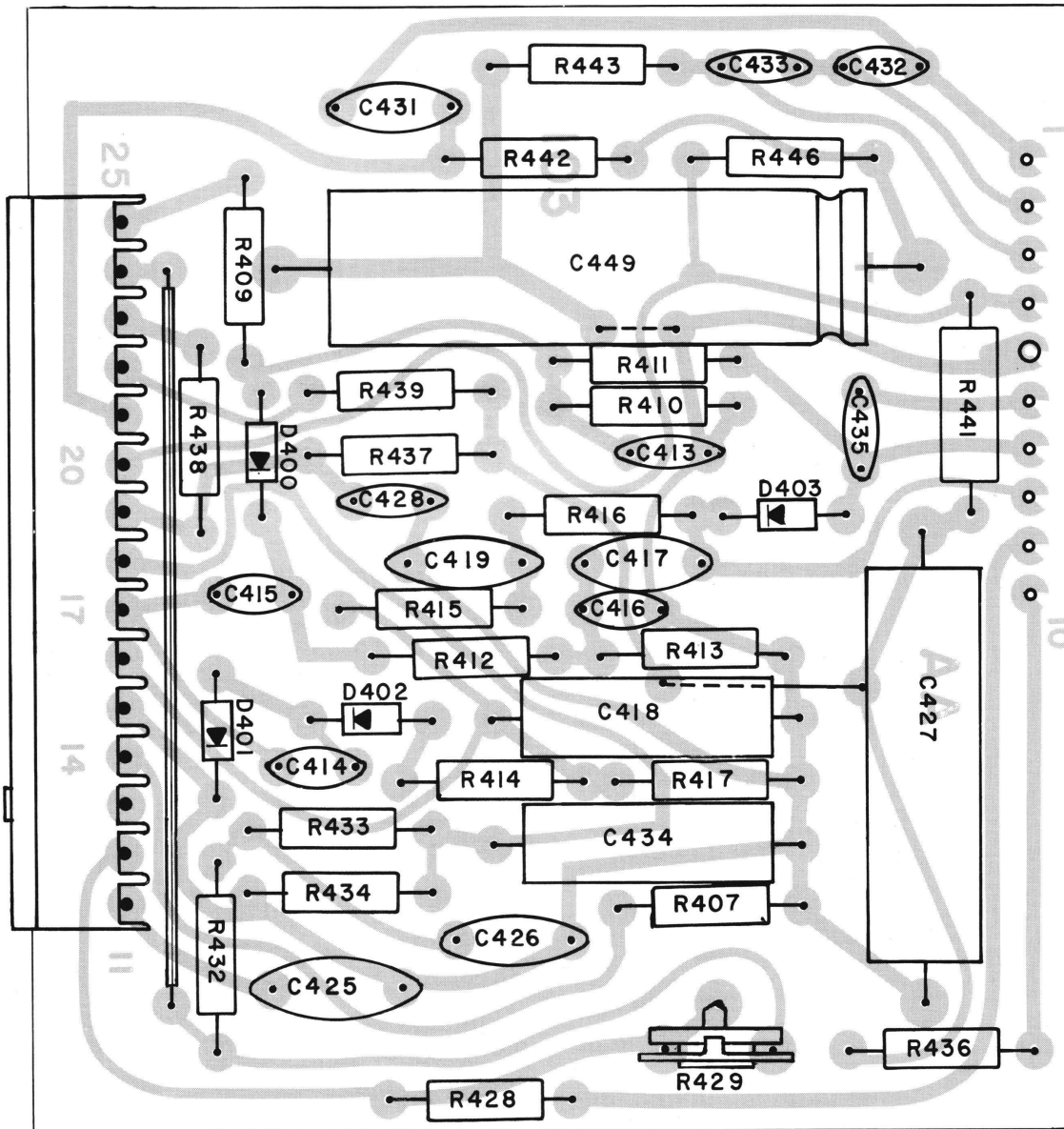

AUX. RECEIVER BOARD PCB AA
Fig. 7

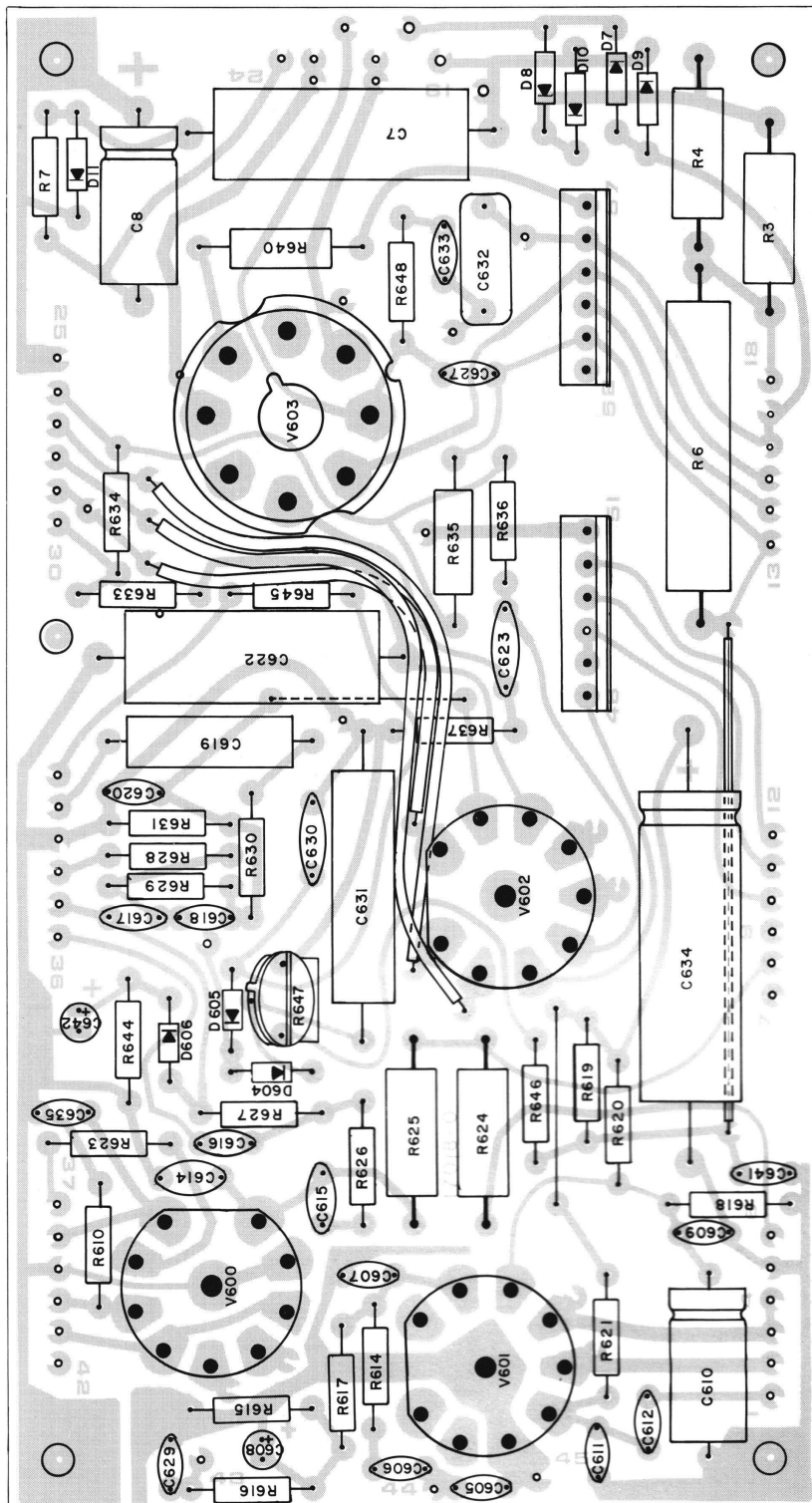

AUDIO BOARD PCB B
Fig. 8

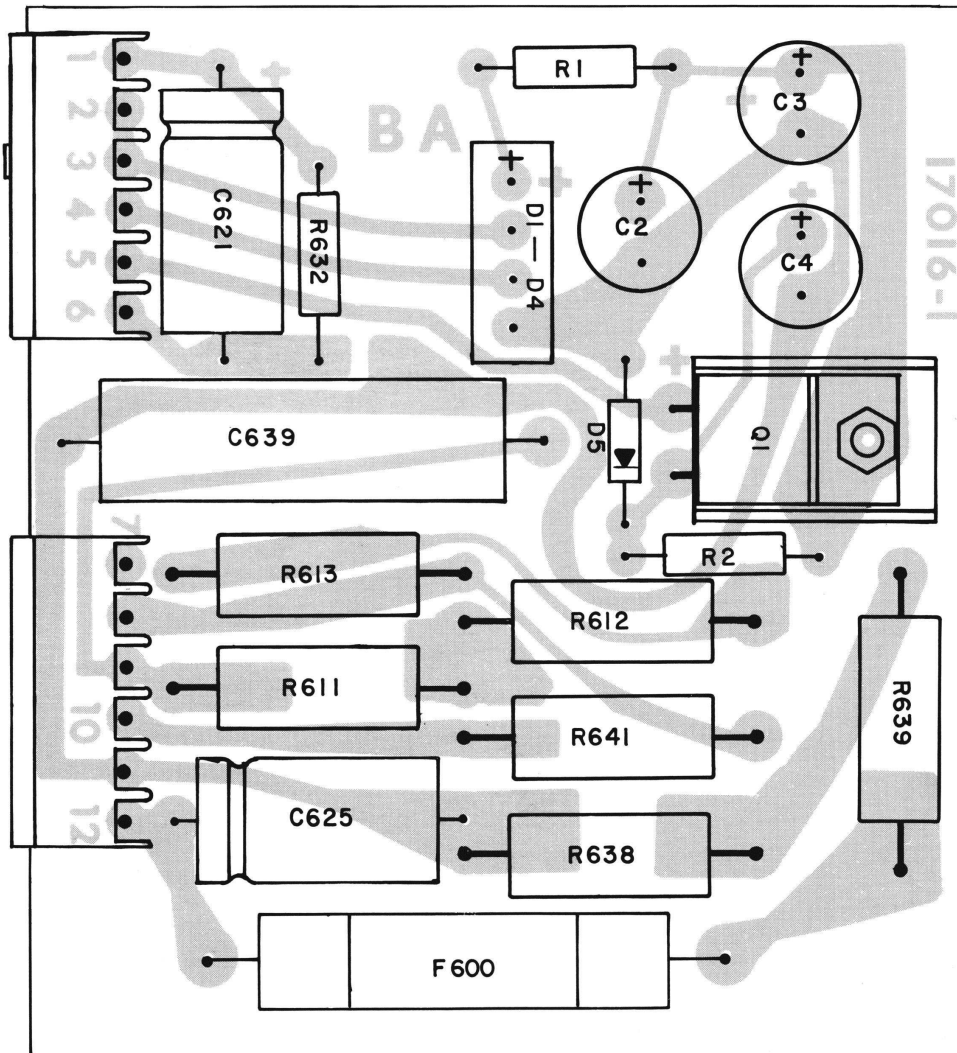

AUDIO AUX. BOARD PCB BA
Fig. 9

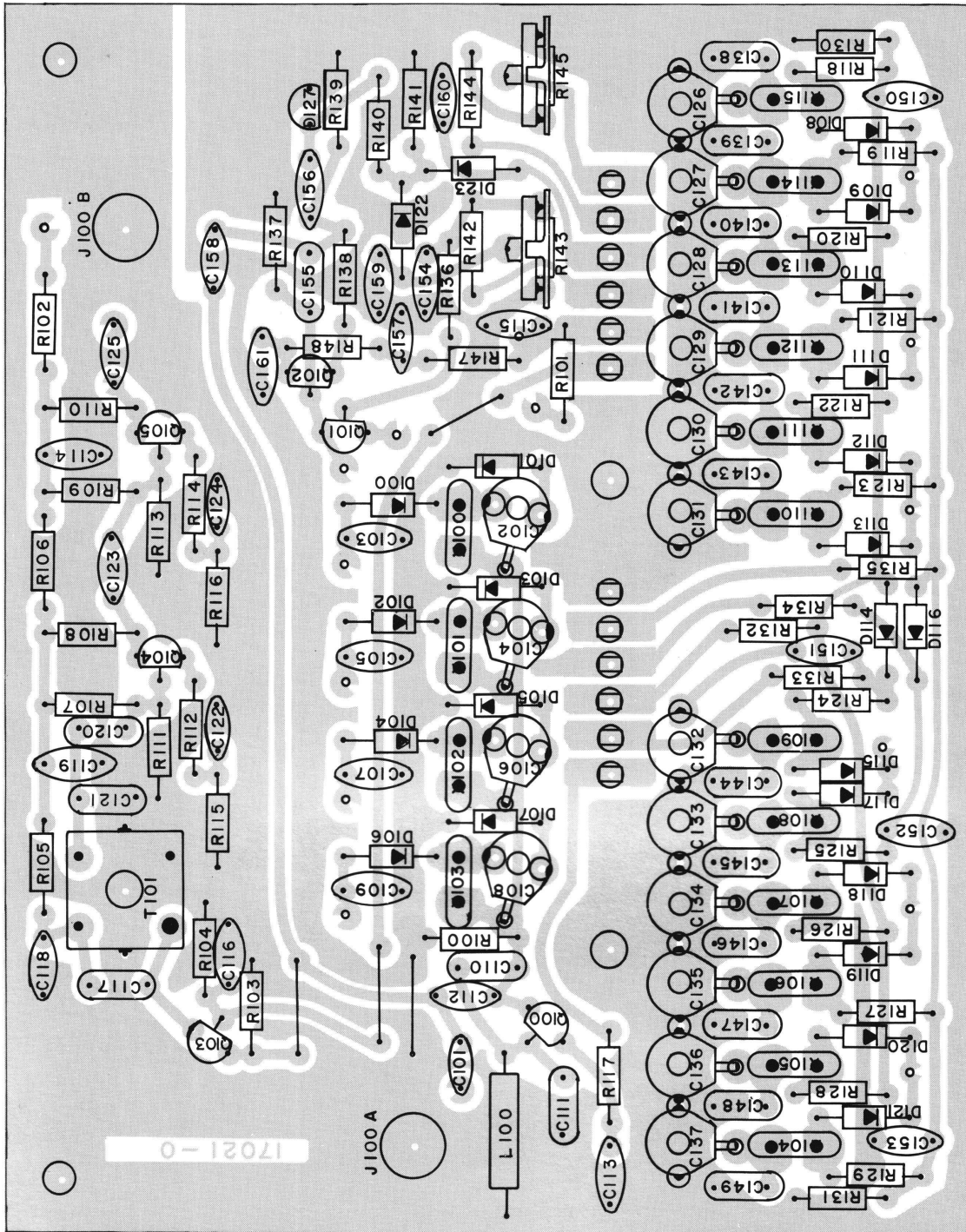

SYNTHESIZER BOARD PCB C

Fig. 10

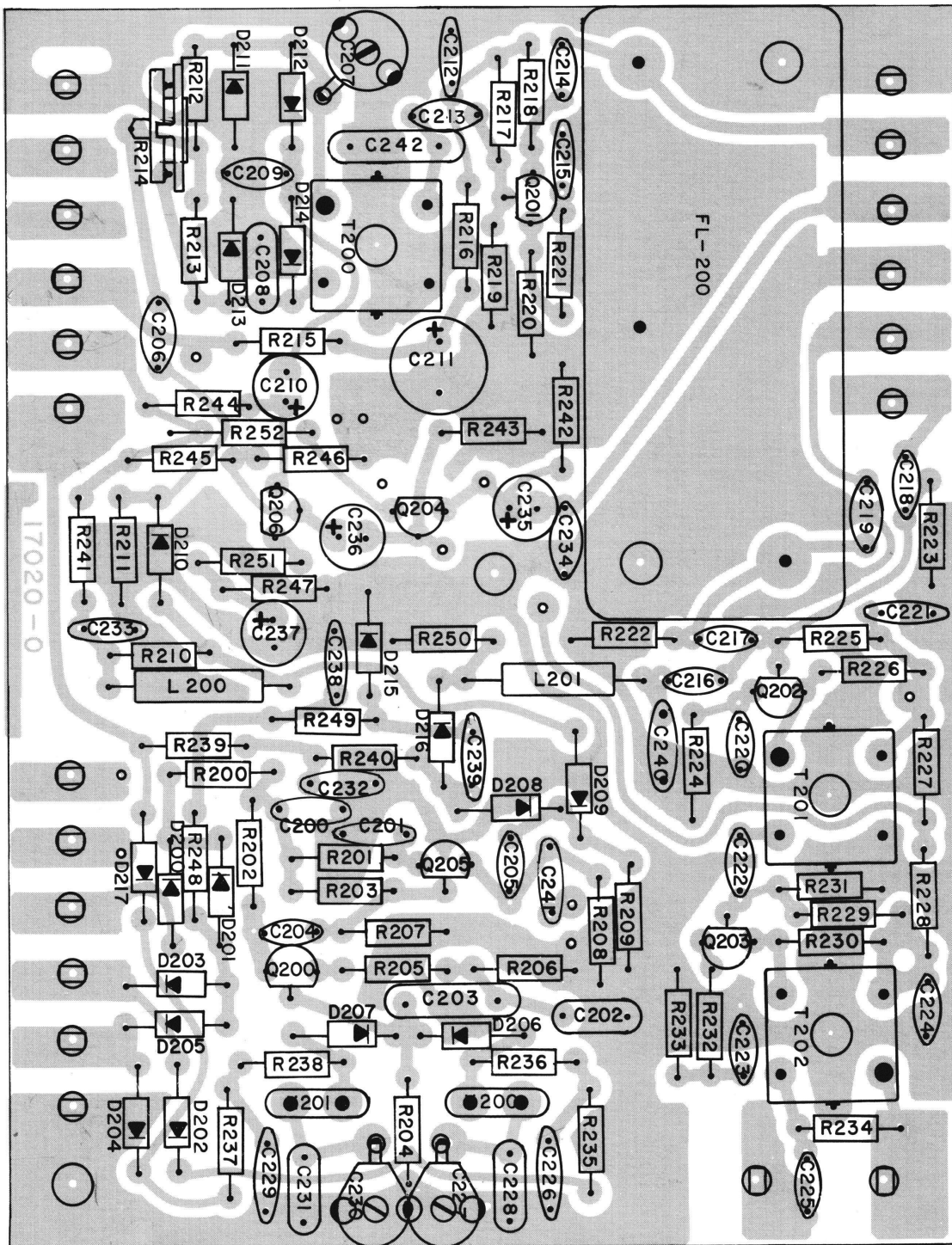

BALANCED MODULATOR BOARD PCB D

Fig. 11

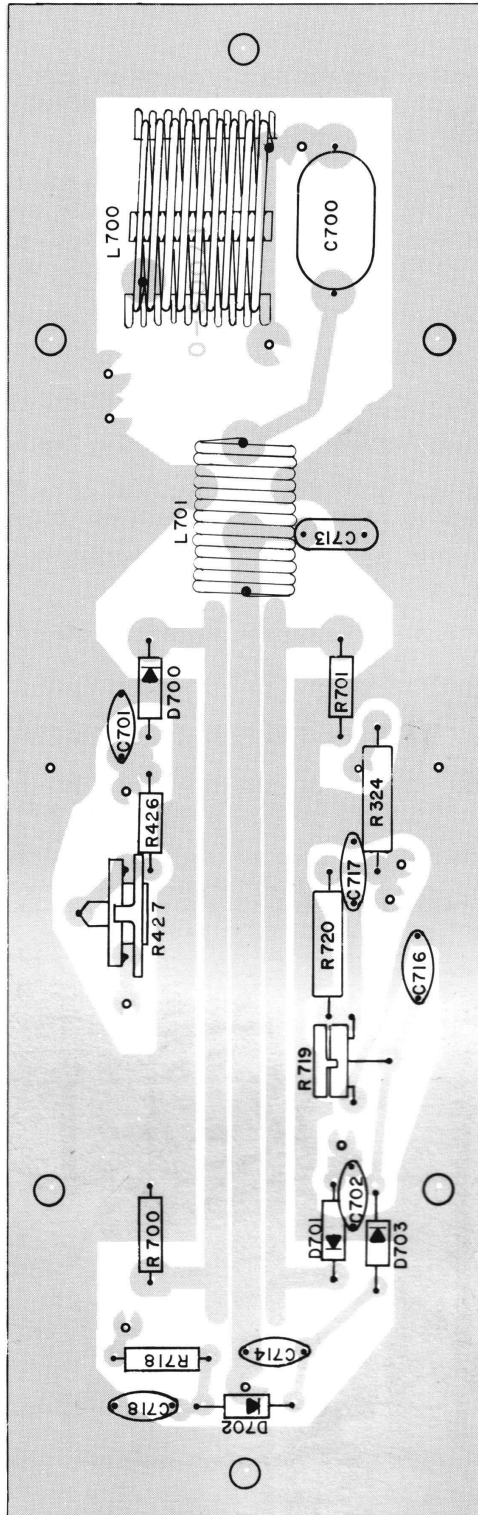

RF BRIDGE BOARD PCB E
Fig. 12

Zeroing the S-Meter

Some drift in the S-Meter zero setting may be experienced before the vacuum tubes and related components stabilize with use. To check and adjust S-Meter zero proceed as follows: (allow 1/2 hour warm-up)

CAUTION Hazardous voltages and high temperatures may be encountered within the D201 cabinet. Keep hands clear of hot tubes and chassis components in general. REMOVE MIC CORD to prevent high voltages from appearing on the RF Board should the Transmitter accidentally be keyed.

1. Place CRYSTAL/MANUAL SWITCH in the CRYSTAL position.
2. Turn the RF GAIN fully CCW.
3. Rotate the CHANNEL SELECTOR to the blank channel between 22 and 23.
4. Place the METER SWITCH in the S/PWR position. The meter should read zero.
5. If adjustment is required, lift the top cover and locate the S-Meter zero control (R422) on the Receiver 'A' board next to the relay K600 as shown in fig. 3.
6. Momentarily defeat the AC interlock on the Top Cover and adjust R422 for a Zero reading on the meter.
7. Close Top Cover and restore controls to normal operating positions.

NOTES ON TUBE REPLACEMENT

1. If V701 is replaced the Final Amplifier circuit will require reneutralization. This procedure must be performed by a First or Second Class F.C.C. license.
2. If V300 is replaced the S-Meter circuit may require calibration.
3. If V401 or V602 is replaced the S-Meter circuit will require zeroing.

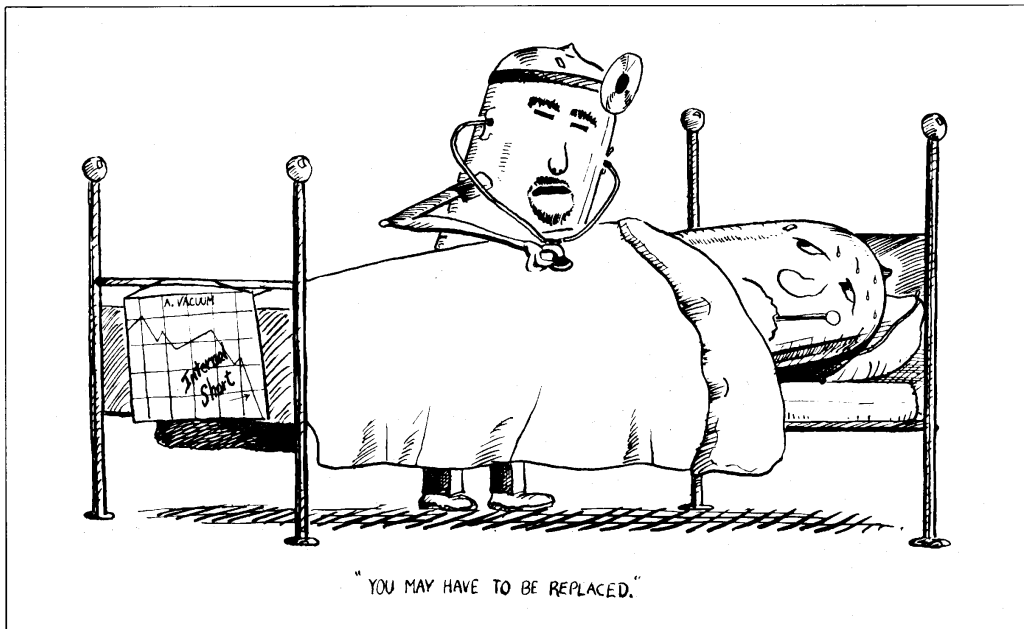

TUBE TROUBLE LOCATOR

MOST PROBABLE CAUSE

SYMPTOM	6BQ7A V 300	6BK7B V 301	6BK7B V 302	6BA6 V 400	6GH8A V 401	12AX7 V 402	6BA6 V 500	6BA6 V 501	6GH8A V 502	6GH8A V 600	6GH8A V 601	6GH8A V 602	6L6 GC V 603	12BY7A V 700	6L6GC V 701
WEAK OR NO OPERATION															
AM AND SSB RECEIVE	○	○				○						○			
AM RECEIVE		○	○	○											
SSB RECEIVE							○	○	○						
MANUAL RECEIVE			○												
AM AND SSB TRANSMIT										○	○		○	○	
AM MODULATION										○	○	○	○		
SSB TRANSMIT/ MODULATION										○	○		○	○	
SSB RECEIVE MICROPHONIC							○	○	○						
IMPROPER S-METER						○			○			○			
SQUELCH						○			○						

RECEIVER FAILURE CHART

Symptom	Possible Cause
1. Receives in SSB but not AM.	V400, V401, FL400. If dead in Manual Receive, V302, T400, T401, X300.
2. Receives in AM, but not SSB.	V500, V501, V502. If no SSB transmit, Balanced Modulator Module.
3. No S-Meter response in SSB receive.	No SSB AGC. Q500, Q501, + 14V power supply.
4. Low gain in all modes, but normal S-Meter readings.	V402, V602, V603. If transmitter modulation is good, V402 only.
5. No audio, but normal S-Meter readings.	Same as above.
6. Low gain in all modes, meter readings low.	V300, V301, Synthesizer Module.
7. No USB receive or transmit.	6.2535 crystal (X200) See fig. 11
8. No AM/LSB receive or transmit.	6.2565 crystal (X201) See fig. 11
9. Every fourth channel dead in crystal receive.	(See trouble crystal chart page 36)
10. Four sequential channels dead in crystal receive.	(See trouble crystal chart page 36)
11. Receives in crystal but not in Manual.	V302, L301, K600, X108, V109.
12. Receives in Manual, but not in crystal.	Synthesizer Module.
13. Erratic or inaccurate Manual Tune.	X108, X109. (See fig. 10)
14. Manual Tuning dial, out of calibration.	See Manual Tuning alignment procedure.
15. Manual tuning dial slips or binds.	Loosen tuning capacitor mounting screws, rotate knob several turns, tighten screws. CAUTION: Never Lubricate or degrease Vernier drive Assembly.
16. Frozen Manual Tuning.	Tuning condenser shaft binding.
17. S-Meter drifts.	V401-V602.
18. Receiver noise increases with Noise Blanker on.	Blanker oscillating. Turn slug of T802 approximately 1/4 to 1/2 turn, until oscillation stops.
19. Feedback at high Volume levels in SSB.	Microphonic Tube: V501, V502
20. Receive and Transmit dead.	Synthesizer Module, 14V supply.

TRANSMITTER FAILURE CHART

Symptom	Possible Cause
1. Low SSB output, AM normal.	Mic. Gain or TTC fully CCW, V601, V600, Balanced Modulator module. If AM modulation is good, suspect Bal. Mod. or ALC adjustment.
2. Low AM & SSB output. Poor modulation.	Improper loading to antenna, V700, V701, Balanced Modulator Module not seated.
3. Transmit OK, but no meter indication.	Ungrounded antenna or fiberglass antenna resulted in static discharge across RF Bridge Board. D700 and/or D701 blown. (see fig. 12)
4. Every 4th channel dead.	4 MHz crystal (see crystal trouble chart p. 36)
5. Four sequential channels.	16 MHz crystal (see crystal trouble chart p. 36)
6. Transmitter quits when clarifier is turned to extreme CCW or CW.	Same as above.
7. Won't unkey, or delay in receive returning.	V600 or K600. C424. High SWR on transmission line.
8. Transmitter dead. Transmitter/rec. dead.	Balanced modulator module, V700, V701. Synthesizer module.
9. No USB transmit.	6.2535 crystal (X200) See fig. 11.
10. NO LSB transmit.	6.2565 crystal (X201) See fig. 11.
11. Carrier on SSB, with fuzzy modulation.	V701 unneutralized. See neutralizing instructions. NOTE CAUTION.
12. Carrier on SSB, with good AM & AM modulation.	Balanced modulator module.
13. Hum on carrier.	Transmitter bias improperly set. C8, C7, D11.
14. Modulation tinny, or too bassy.	TTC or microphone head faulty.
15. Low power out, High SWR.	Antenna cable, antenna.

FUSES

Circuit protection is provided by four fuses:

1. F1 is the primary fuse. (3MDL) See fig. 2.
2. F2 is the low voltage fuse. (AGC1) See fig. 3.
3. F3 is the 6.3V filament fuse. (A short piece of #28 bus wire one inch long) See fig. 5.
4. F600 is the Aux. Audio Board protection fuse. It is a 0.1A pigtail type. (See fig. 9) This fuse is a failsafe device. Should it blow the D201 should be returned to an authorized factory service center. **Never** replace this or any other fuse with one of larger value.

LAMPS

The dial lights in the D201 are #47 pilot lamps. Replacing these lamps necessitates removal of the reflective light shield. It is important that it be properly positioned when reinstalled. To reinstall the shield:

1. Slide the shield between the CRYSTAL SELECTOR SWITCH and its mounting bracket.
2. Slide right end of shield down on to MANUAL TUNING bracket. **BE SURE** bracket edge fits into slot in bottom of shield.
3. Tuck top edge of shield under lip on front panel and work in until vent holes are directly over pilot lamps.

Troubleshoot & Alignment

General Information

WARNING The following alignment instructions are for qualified technicians only. Improper adjustments will result in degraded performance and may damage certain components. Obvious tampering will void our warranty.

Alignment should not be attempted until all other possible causes of faulty operation have been identified and corrected.

Refer to Figs. 4-12 for component locations.

WARNING Transmitter adjustments may be made only by, or under the immediate supervision of, a person holding an F.C.C. first or second class radio operator license. (This applies specifically to modulation, power, and frequency determining circuits)

Test Equipment

Alignment should be performed using reliable, accurate equipment, as listed below.

DC VTVM-RCA Voltohmyst WV-77E or equivalent.

OSCILLOSCOPE-Hewlett-Packard HP-180A or equivalent.

AUDIO SIGNAL GENERATOR-Hewlett-Packard HP-209A or equivalent.

RF SIGNAL GENERATOR-Hewlett-Packard HP-606 or equivalent.

ELECTRONIC FREQUENCY COUNTER-Hewlett-Packard Model 5248L or equivalent.

50 OHM DUMMY LOAD-Bird Model 52839 or equivalent.

RF WATTMETER-Bird Model 43 or equivalent.

High Voltage Power Supplies

The D201 uses two power supplies, producing 410 VDC & 14.4 VDC. In addition a dropping circuit provides 270 VDC.

The 410 VDC is supplied through diode bridge D7-D10, filtered by C5a, b, c, and switched through K600 to various points in the radio.

Dropping circuit R8, R9 and D6 develops 270 VDC. This voltage is used throughout the receiver and should contain less than 20 MV PP ripple.

14.4 VDC is supplied by D1-D4, filtered by C2, C3, and C4 and regulated by the zener diode/transistor combination of D5 and Q1. All solid state circuits run off the 14V supply and frequency standards are dependent on its accuracy. 10 MV PP ripple is maximum allowable for this supply.

If the radio blows the primary fuse or if troubles occur in the H.V. supply care must be taken to isolate any short circuits in the B+ line. D6 through D11 should be checked for forward/reverse resistance and a careful visual inspection of all associated components made. Particular attention should be given to IF transformers and vacuum tubes for internal short circuits.

Low Voltage Supply Troubles

If problems occur in the 14V supply, D1 through D5 as well as associated filter capacitors should be checked. If the 14V supply is running beyond the tolerance established for it, (14.4 \pm 0.4V), D5 should be replaced. If proper operation is not restored Q1 should be suspect.

NOTE: All supply voltage dependent on 117 VAC input.

Synthesizer

General Information

The synthesizer board is the main frequency determining element for both transmit and receive modes. It consists of 2 oscillator circuits running at 4.4 MHz and 16 MHz, a mixer circuit, and a 20 MHz amplifier circuit. Sixteen crystals provide frequency standards for all crystal controlled functions on each of the 23 channels in AM/LSB and USB, as well as a 4 MHz signal used in manual receiver calibration and a 16 MHz signal used in the Manual Tune mode.

Synthesizer defects may be best characterized by complete loss of Receive and Transmit, low signal levels or no tuning action at T100. Suspect the Synthesizer only after determining that a tube is not at fault. Circuit alignment and frequency calibration requires proper test equipment and must be performed by a licensed technician.

Should crystal replacement, alignment and calibration not restore proper operation, the entire board should be returned to the factory for full service.

WARNING According to F.C.C. Regulations, only a person holding an F.C.C. First or Second Class Commercial license may perform the alignment procedures outlined for the Synthesizer module.

Circuit Description – Synthesizer

The Synthesizer Board consists of two oscillators, a mixer, a 20 MHz amplifier and diode switching circuits used to select the various crystals and modes of operation.

The output of the 4 MHz oscillator Q100 is mixed with the output of the 16 MHz oscillator (Q102) at the gate of mixer FET Q103. The output of this mixer is tuned at 20 MHz by T101, amplified by Q104 and Q105 and fed out jack J100B. Crystal selection is accomplished by S3 and the action of the diode switching circuits. In the various modes switching voltages will be present at the pins on the Synthesizer main power plug. Failure of these voltages to appear may indicate problems in the associated diode switch circuits. (See pin voltage chart for specific values)

The Synthesizer Board also provides a 4 MHz signal used in manual receive calibrate and a 16 MHz signal used in the manual tune mode.

Synthesizer Crystal Trouble Chart

Crystal designation
By schematic number

AM & LSB	Every 4th Channel				USB
	X100	X101	X102	X103	
X105	1	2	3	4	X104
X107	5	6	7	8	X106
X109	9	10	11	12	X108
X111	13	14	15	16	X110
X113	17	18	19	20	X112
X115	21	22		23	X114

–Channel Numbers–

Use of Crystal Trouble Chart

1. Determine channels involved and sequence of failure:
 - A. If a group of 4 consecutive channels, use left or right index.
 - B. If every 4th channel, use top index.
2. Determine mode in which failure occurs:
 - A. For AM/LSB failures, use left index.
 - B. For USB failures, use right index.
3. If channel failure does not occur on every 4th channel or in groups of 4, synthesizer crystal problems are unlikely. (The Synthesizer should be returned to the factory for service if this is the case.)

Notes on crystal replacement

Tram/Diamond Corporation can certify continued operation to F.C.C. requirements only if replacement crystals are obtained from the factory. If evidence of general off frequency operation is detected or if replacement crystals do not restore proper operation, service or recalibration to restore proper operation must be performed by a technician with a First or Second Class Commercial license as required by Part 95 of the F.C.C. rules and regulations.

Anytime a crystal requires replacement, the Synthesizer Board must be removed from the radio. Proper procedure for Synthesizer removal is outlined below and should be followed to prevent damage to the Synthesizer Board and associated components.

Synthesizer Pin Voltage Chart:

— PIN —

Mode	1	2	3	4	5	6	7	8	9	10	11	12
Xtal Rec. AM	1.5	14	4.7	0	14V	2.3	GND	0	0	14	13	14
Xtal Rec. USB	1.5	14	4.7	0	14V	2.3	GND	14	13	0	0	14
Man. Rec. AM	0	0	0	14	14V	2.3	GND	0	0	0	13.5	0
Man. Rec. USB	0	0	0	14	14V	2.3	GND	0	14	0	0	0
Xtal Xmit AM	1.5	13.6	4.7	0	14V	2.3	GND	0	0	14	13.5	14
Xtal Xmit USB	1.5	13.6	4.7	0	14V	2.3	GND	14	12.4	0	0	14
Man. Xmit AM	1.5	13.6	4.7	0	14V	2.3	GND	0	0	13.5	12.5	13.5
Man. Xmit USB	1.5	13.6	4.7	0	14V	2.3	GND	13.6	12.4	0	0	13.5
Rec. Cal. "Out"						2.3						14

- NOTE: 1. For pin location see Synthesizer inset on schematic.
 2. All voltages \pm 5% with plug connected to board.
 3. Clarifier set at 12 o'clock (4.75V @ pin 3).

4 MHz Calibrate

1. Connect a frequency counter directly to J100A.
2. Remove plug from J100A.
3. Set CRYSTAL MANUAL switch to CRYSTAL, CRYSTAL SELECTOR to channel indicated. Adjust appropriate 4 MHz crystal calibration capacitor as follows:

CHANNEL	SELECTED 4 MHz CRYSTAL	CAL CAP	FREQUENCY (MHz)
1	4.400	C102	4.40000
2	4.410	C104	4.41000
3	4.420	C106	4.42000
4	4.440	C108	4.44000

20 MHz Calibrate

1. Set CLARIFIER to 12 O'Clock position. (4.75V on pin 3)
2. Mode to CRYSTAL, CHANNEL as required.
3. Connect a frequency Counter directly to J100B. Adjust as indicated.

CHANNEL	MODE	CAL-CAP	FREQUENCY (MHz)
1	AM	C137	20.7085
1	USB	C136	20.7115
5	AM	C135	20.7585
5	USB	C134	20.7615
9	AM	C133	20.8085
9	USB	C132	20.8115
13	AM	C131	20.8585
13	USB	C130	20.8615
17	AM	C129	20.9085
17	USB	C128	20.9115
21	AM	C127	20.9585
21	USB	C126	20.9615

20 MHz Mixer

- a. Select Channel 17.
- b. Connect a DC VTVM to Pin 8 V301.
- c. Tune T100 to top peak, and top and bottom slugs of T101 for maximum DC. (If T101 is badly detuned, it may be necessary to connect an oscilloscope to J100B and tune T101 for a 20 MHz signal. The oscilloscope should then be removed and T101 slugs peaked for maximum DC voltage.)

Manual Receive Synthesizer Calibration

- a. Remove the 4 MHz manual oscillator cable from J100A.
- b. Connect the frequency counter to Q103 Gate.
- c. Place the D201 transceiver in the manual receive LSB mode.
- d. Adjust R143 for 16.408500 MHz.

Synthesizer Module Replacement

TRAM/DIAMOND CORPORATION has designed the synthesizer module with the technician in mind; should the D201 ever become inoperative due to a synthesizer defect, the technician may simply remove the module and forward it to the factory for replacement or repair.

Note that both the Balanced Modulator and Synthesizer modules contain adjustable components. Every care must be taken in the removal, packaging for shipment, or the installation of these modules to see that adjustments are not disturbed.

Synthesizer Module Removal

1. Remove retaining screw in center of Balanced Modulator Board.
2. Lift board away from terminals being careful not to bend any.
3. Set the channel selector switch to blank channel.
4. Remove the 3 plugs from the Synthesizer Module.
5. Remove the spacer nuts which secure the module to the selector switch.
6. Pull back and carefully jiggle the module to remove it from the retaining screws.

Synthesizer Module Installation

1. Set the channel selector to blank channel position.
2. Slide Synthesizer Module over retaining screws.
3. Install spacer hex nuts and tighten.
4. Install the phono plugs and cable plug.
5. Re-install the Balanced Modulator board by pushing down on the board, seating all terminal pins and firmly tightening mounting screw.

Synthesizer Module Return

If it becomes necessary to return the Synthesizer Board to the factory for service, several precautions should be observed.

1. The board must be adequately protected to withstand the rigors of shipping. Packaging should be 2" thick on all sides and firmly hold the board in place.
2. The board should be insured against loss for \$100.00.
3. A detailed note indicating the type of failure should accompany the board and make mention of the mode and channels involved.

D201 Receiver

General Information

The D201 uses a high gain, multi-mode, super-heterodyne receiver. In the AM mode dual-conversion at 6.25 MHz and 455 KHz occurs using two separate ceramic filters to insure best selectivity and adjacent channel rejection.

In the sideband mode single conversion at 6.25 MHz in conjunction with Product Detection and a steep sided 2.1 KHz, 6 pole crystal filter combine to give an extremely sharp and sensitive receiver.

Normal tube replacement does not necessitate re-alignment.

Circuit Description – S-Meter

The S-Meter circuit is a balanced bridge type configuration between V401B and V602B. DC voltages developed by the AM and sideband detectors are applied to the grid (pin 9) of the V401B. The resulting imbalance drives the meter. Zero balance is achieved through R422, S-9 calibrate through R429.

S-Meter Calibrate

The S-Meter circuit in the D201 may require recalibration if V300 is replaced or if the meter is reading inaccurately on incoming signals. Calibration of the circuit is accomplished using a calibrated Signal Generator as follows:

1. Allow 1/2 hour warm-up.
2. Set mode to CRYSTAL.
3. Zero the meter. (See page 30)
4. Adjust RF Gain fully CW.
5. Connect a calibrated RF signal generator to the D201 antenna jack.
6. Place the D201, in AM receive, Crystal Selector to channel 13.
7. Set generator output at 50 microvolts on channel 13.
8. Adjust R429 (S-Meter sensitivity) for an S-9 reading on panel meter. (See fig. 7 for component location)

Circuit Description – AGC

AM – Control voltage for V300, V400 and V401 is obtained from the diode combination D401 and D402. Negative voltage developed by these diodes in the presence of signal is fed to V300 pin 3, V400 pin 1 and V401 pin 2.

Single Sideband — Detected audio of V502A is applied to and amplified by the other half of this tube, V502B. Further amplification is accomplished by Q500. At this point the Sideband receive signal is picked off and fed to the audio stage. A portion of this signal is also applied to the base of Q501. Here the resulting voltage at the emitter is rectified by D500 and D501 with a negative AGC potential resulting. This voltage, when applied to V300, V400, and V401, controls the gain of each. The R/C combination C424/R430 supply fast-attack, slow-decay characteristics for the SSB AGC circuit.

Squelch

The front panel squelch control and the AGC voltage determine the squelch condition in the D201. Voltages sampled at S3B pin 1 are fed to pin 7 of V402B where they are used to bias off this tube. When the receiver is squelched, V402b is conducting and V402A is cut off due to the increased bias voltage at its grid. A negative AGC signal will bias V402B reducing

plate current. The resulting drop in bias at V402A pin 2 places it in conduction. Signal is passed when AGC voltage is present. The receiver returns to a squelched state when AGC signal is removed.

AGC Check

If local signal overload is a problem, or erratic S-Meter readings are observed, the AGC circuits may be at fault. Both the AM and Sideband portions of the D201 receiver have AGC generation capability and should be treated independently.

To check the AGC functions in the AM mode proceed as follows:

1. Allow five minutes warm-up time.
2. Set mode to AM.
3. Set RF Gain fully CW.
4. Connect a VTVM to S3B pin 1. (green/white lead)
5. With no signal input at the antenna approximately +0.3VDC should be observed.
6. With 50 microvolts input at the antenna $-4\text{VDC} \pm 1\text{VDC}$ should be observed.

If AGC voltage is not present, or is low, the AGC diodes D401 and D402 may be faulty. The AM AGC voltage can be observed at the grids of V300, V400 and V401. If present here with no AGC action, one of these tubes may be at fault.

To check AGC functions in the sideband mode proceed as follows:

1. Allow five minute warm-up time.
2. Set mode to USB or LSB.
3. Set RF Gain fully CW.
4. Connect a VTVM to S3B pin 1. (white/green lead)
5. With no signal input observe approximately +0.3VDC.
6. With a 50 microvolt input at the antenna observe $-2.8\text{VDC} \pm 1\text{VDC}$.

Most Sideband AGC failures are characterized by a complete lack of S-Meter readings in the Sideband mode. If this is the case Q501 should be suspect. D500 and D501 may also be faulty.

Manual Tuning Calibrate

The manual tuning portion of the D201 receiver may require calibration and alignment if significant inaccuracies are observed in the manual dial position. This procedure should be performed after the D201 has reached operating temperature and stabilized. A warm-up period of one hour is mandatory to insure accurate calibration.

After a one hour warm-up proceed as follows:

1. Check the mechanical dial to variable capacitor setting. The capacitor, C317, should not reach either of its own stops. Its rotation should be limited by the stop screw located in the dial hub.
2. Connect a frequency counter, through a 5 pf cap, to J100a.
3. Set CRYSTAL/MANUAL Switch to MANUAL.
4. Set CRYSTAL SELECTOR and MANUAL TUNING each to channel nine.
5. Pull CAL switch out. (ON).
6. Tune L301 for an audio zero-beat. (freq. 4.400 MHz) See fig. 3

7. Set MANUAL DIAL for 27.450 MHz, adjust C319 for 4.785 MHz.
8. Repeat steps 6 and 7 until both lower and higher readings are correct.

TUNE	MANUAL DIAL	FREQUENCY (MHz)
Coil (L301)	9	4.400
CAP C319	27.450	4.785

Circuit Description – 27MHz RF Amplifier

27 MHz signals enter the radio through J1, pass through K600 via pin 14, through RF Gain control R326 and are fed to antenna transformer T300. T300 feeds the grid of V300 the RF amplifier. V300 is a cascode connected dual triode which is neutralized by L300. T301 couples the 27 MHz output of V300 to the grid of the first mixer, V301. At this point a 20 MHz signal supplied by the synthesizer module and coupled through T100 is also applied. Mixing results in a 6 MHz signal which is tuned by T302. Depending on the mode of operation, this 6 MHz signal may be applied to either FL200 on the Balanced Modulator board in the SSB mode, or the second mixer, V302, in the AM mode.

In the AM mode mixing of the 6 MHz IF signal and the receiver local oscillator running at 5.8 MHz at the grid of V302 results in the 455 KHz AM IF signal.

R.F. Amp. and Receiver Mixer Alignment

Low gain observed in both the AM and SSB modes may indicate the need for alignment of the front end and mixer circuits. If alignment is necessary proceed as follows:

1. Connect an RF signal generator to the antenna jack. Adjust generator modulation for 30% at 1 KHz.
2. Place D201 in CRYSTAL receive, AM mode.
3. Set RF Gain fully CW.
4. Set CHANNEL SELECTOR to 13. (except as noted in step 8)
5. Set CLARIFIER at 12 o'clock position.
6. Observe audio output at external speaker jack through a 4 Ohm termination.
7. Peak T300 for maximum indication using top peak of can. Peak T302 for maximum indication. Peak T301 for maximum indication.
8. Set D201 Crystal Selector and RF Signal Generator to channel 23. Detune top slug of T301 for a 15 db drop in audio output. Peak bottom slug of T301.
- 10.9. Set D201 Crystal Selector and RF signal Generator to channel 1. Peak top slug of T301 for maximum audio output.

If R.F. Amp and Mixer circuits won't align properly and low gain or intermittent condition persists in both the AM and Sideband modes routine signal tracing may isolate failures of T300, V300, T301 or V301. Signal injection levels are noted on the schematic at all feasible injection points. Audio output at the external speaker jack should be at least 2V RMS for injection values indicated.

NOTE: All double tuned IF transformers should be tuned with slugs toward the ends of the can.

455 KHz AM IF: Circuit Description

The AM IF strip consists of V302, the second mixer, two Ceramic filters, V400, the first AM IF amplifier, T400, V401 the second AM IF amplifier, and T401.

6.25 MHz IF signals mixed at the grid of V302 with the 5.80 local oscillator result in the 455 KHz IF signal. This signal is amplified, filtered and applied to the first AM IF AMP. Further tuning and amplification by T400 and V401 results in IF output at T401. This output is then fed to the detector diode D400.

455 KHz AM IF Alignment

Low gain observed in the AM mode only may indicate the need for alignment the 455 KHz IF. If alignment is necessary proceed as follows:

1. Connect an RF Signal Generator ($455 \pm 1\text{KHz}$) through a 0.01uf capacitor to V302 pin 2. Adjust generator modulation for 30% at 1 KHz.
2. Set RF Gain fully CW.
3. Observe audio output of D201 with a VTVM through a 4 ohm termination at the external speaker jack. (The D201 S-Meter can be used as an indicator for IF peaking if an unmodulated signal generator is used).
4. Adjust generator for a usable meter indication.
5. Tune L400, T400 and T401 for greatest meter indication. It will be necessary to reduce the generator level as each coil is tuned to permit more accurate alignment. Note that both top and bottom slugs are to be tuned in T400 and T401.

NOTE: All double tuned IF transformers should be tuned with slugs toward the ends of the can.

If the AM IF won't align properly and low gain or intermittant condition persists in the AM mode, routine signal tracing may isolate failures of: V302, the 455 KHz filter, V400, T400, V401 or T401. Signal injection levels are noted on the schematic at all feasible injection points. Audio output at the external speaker jack should be at least 2V RMS for injection values indicated.

Sideband 6 MHz IF: Circuit Description

The 6 MHz output of the First Mixer V301, is fed to pin 16 of the Balanced Modulator board. It passes through the bilateral filter FL200, (a six pole, 2.1KHz crystal type) and is fed out through pin 19 to T500. T500 feeds the grid of V500, the first sideband IF amplifier, and the resulting signal is applied to T501 which in turn feeds V501, the second sideband IF amplifier. The 6 MHz Carrier BFO signal is inserted at V502 pin 8. Product detection results in audio output, which in turn, is used to generate sideband AGC voltages.

Sideband 6 MHz IF: Alignment

Low gain observed in the Sideband mode only may indicate the need for alignment of the 6 MHz Sideband IF. If alignment is necessary proceed as follows:

1. Connect an RF signal generator to the Antenna jack. (no modulation)
2. Place D201 in USB receive, Channel 13.
3. Set RF Gain fully CW, CLARIFIER to 12 o'clock.
4. Adjust generator for a meter indication at the external speaker jack. Level should be adequate for tuning, and frequency 1.5 KHz at output.
5. Tune T500, T501 and T502 for maximum indication, reducing the generator level as required.

6. With generator input of 0.1 microvolts, observe at least 2V RMS audio output.

If 6 MHz IF won't align properly, and low gain or intermittent condition persists in the Sideband mode routine signal tracing may isolate failures of T302, the Balanced Modulator, T500, V500, T501, V501, T502 or V502. Signal injection levels are noted on the schematic in both the 27 MHz and 6 MHz sections of the Sideband receiver circuits. Audio output at the external speaker jack should be at least 3V RMS for the injection values indicated.

RF Noise Blanker: Circuit Description

The D201 uses an RF Noise Blanker to eliminate impulse type noise. This device detects, amplifies and rectifies noise pulses which are then used to ground the receiver input at the First Mixer.

Noise is sensed at the primary of T300 and coupled through T800 at 25 MHz. IC800 amplifies the 25 MHz signal and applies it to T801. T801 tunes the signal at 25 MHz and applies it to the base of Q800. Positive going pulses turn on Q800 and drop the collector voltage toward zero. This drop in voltage is seen at the base of Q801 which turns off with a resulting collector swing to +14 VDC. This 14 VDC, dropped through R807, is applied to the base of Q802 which instantaneously turns on, dropping its collector voltage to zero. As the collector voltage of Q802 approaches zero the reverse bias is removed from D800, a 1N67A. With its bias removed the diode effectively shunts all signals to ground through Q802 for the duration of the noise pulse. The result of this switching is extremely short duration "holes" in the received signal coinciding with the noise pulses. By detecting the noise impulses before the selective and high-gain circuits of the receiver, noise pulse duration and therefore "hole" duration, is kept to a minimum.

RF Noise Blanker: Alignment

If inadequate blanking action is observed, the Noise Blanker may be in need of alignment. To align the Blanker circuit proceed as follows:

1. Set power on, Mode to CRYSTAL.
2. CHANNEL SELECTOR to blank channel.
3. BLANKER on (pulled out)
4. Connect a VTVM to R802/Q800 junction and adjust R802 for +0.4VDC. (See fig. 6)
5. Place probe on base of Q802.
6. Connect a signal generator to the antenna jack and adjust output for a 25 MHz signal with 1KHz, 30% modulation.
7. Increase generator output until VTVM indication is obtained.
8. Alternately tune T800 and T801 for peak reading on the meter. Reduce generator level to keep meter reading less than +0.5VDC. T800 and T801 will normally tune with slugs near top of cans.
9. Repeat step 8 until T800 and T801 are peaked at the minimum output level from the generator necessary for a reading of +0.3 VDC on the VTVM. A generator level of 250 microvolts (48db) is maximum allowable for adequate blanking. 40db is nominal.

CAUTION: When fully peaked the Blanker may oscillate with the antenna jack terminated in 50 ohms. If this is the case additional noise will be observed when the Blanker is activated in the Sideband mode. A slight detuning of the Blanker circuit (1/4 to 1/2 turn of T800) is required to stop this high-gain oscillation. The blanking efficiency will not be reduced by this slight detuning.

If alignment does not restore blanking action, or the Blanker does not respond to input signals D800 may be open or failures in the transistor amplifier or switching circuits may be found.

AM Noise Limiter: Circuit Description

The D201 uses a low level, series gate type, audio frequency Noise Limiter. A normally conducting, forward biased diode, D403, is connected in series with the AF line between the Detector and first audio amplifier. Under normal signal and low noise conditions detected audio is passed and fed to the audio amplifier. When a short duration, high level noise pulse rides in on the detected audio the limiting diode is forced into nonconduction by the negative voltage developed at the detector and applied through R411. Thus the signal path is blocked for the duration of the noise pulse since the AGC cannot respond quickly enough to raise the voltage at R416. R431 adjusts the amount of resistance seen by the incoming audio and therefore the level of bias on D403. This varies the limiting ability of the circuit.

Since the limiting diode reacts to any high-level signal the audio from extremely strong stations will be distorted slightly by the signal blocking process.

Receiver Audio

The receiver audio strip in the D201 is comprised of V402, the first audio amplifier, V602 the audio driver, and V603, the audio power amplifier. If S-Meter indications are normal, but there is no audio output at the speaker, trouble is indicated in the receiver audio circuits. These circuits may be checked by injection of signals indicated on the schematic. Failures of V402, V602, V603 or associated circuitry can be isolated in this manner. An audio output of at least 2 VRMS should be observed at the external speaker jack with injection valued indicated.

Transmitter

General Information

The D201 transmitter uses a Class C Final amplifier with plate and screen grid modulation in the AM mode. A compression circuit controlling the Audio Gain at V601 insures 95% modulation for widely varying input signals.

In the single sideband mode a Balanced Modulator/Filter combination generate either upper or lower sideband signals which are automatically level controlled (ALC) to insure a full 12 watt PEP output with low intermodulation distortion. RF final amplification takes place using vacuum tubes in Class AB₁ operation.

Power sensing and SWR measurements are supplied by directional detector circuits on the RF Bridge Board. TVI filtering also occurs on the RF Bridge Board to insure a minimal amount of radiated harmonic interference.

WARNING The following alignment instructions are for qualified technicians only. Improper adjustments will result in degraded performance and possibly permanent damage to certain components. Obvious tampering will void the warranty.

Alignment should not be attempted until all other possible causes of faulty operation have been identified and corrected.

Refer to Figs. 4-12 for component locations.

WARNING Transmitter adjustments may be made only by, or under the immediate supervision of, a person holding a First or Second Class Radio Operator License. (This applies specifically to Transmitter Alignment.)

Power Metering Circuit Description

The D201 uses a directional detector system to sample power in the forward and reverse direction. Forward power is indicated directly in watts on the S/PWR scale of the meter. Reverse power is translated into SWR and displayed on the SWR scale. In the forward direction induced current flows through the forward biased D700 where DC is picked off and fed to S5-pin 11.

In the reverse direction induced currents flow through D701 where DC is picked off and fed to S5-pin 12. The detected DC voltage is fed to the grid of V401B via S5 causing the meter to deflect.

Power Meter Calibrate:

The power meter on the D201 may occasionally require recalibration. To accomplish this, proceed as follows:

1. Allow 5 minutes warm-up.
2. Set mode to AM, channel selector to 11.
3. Microphone gain fully CCW.
4. Zero the meter (see page 30)
5. Connect wattmeter to antenna terminal.
6. Observe reading on external PWR meter in transmit.
7. Adjust R427 so that D201 panel meter reads the same as external meter.

WARNING The procedures outlined below may only be carried out by those with First or Second Class F.C.C. Commercial Licenses.

RF Driver, RF Final Amplifier and Neutralization

1. Remove B+ from V701 (RF Final) by disconnecting the orange wire from the junction of L704-C720.
2. Connect a 50 ohm dummy load and RF wattmeter to the D201 antenna jack.
3. Connect a DC VTVM to the junction of L702, C719 and R709 and R710.
4. Place D201 in AM receive and adjust R708 (AM bias) for -24 VDC.
5. Place D201 in LSB receive and adjust R707 (SSB bias) for -32 VDC.
6. Place D201 in Channel 13 AM transmit.
7. Retune T700 for maximum DC indication.
8. Place D201 meter switch in SWR CAL position, SWR CAL control fully CW, C712 (RF Final Load Capacitor) one turn from maximum capacitance (1 turn from full CCW from backside of D201 chassis).
9. Tune C711 (RF FINAL TUNE capacitor) for maximum SWR CAL meter indication (meter reading may be small but visible).
10. Tune C706 for a null on the D201 meter.
11. Place D201 in receive and reconnect the V701 B (orange wire).
12. Place the meter switch in S/PWR position and D201 in AM transmit.
13. Retune C711 and C712 for maximum power output (3.8-4.2) watts.
14. Adjust R427 (Power Cal) for the D201 power meter reading to agree with external wattmeter.

Circuit Description – Balanced Modulator Board

The Balanced Modulator Board is used to generate the carrier signal for AM transmit, the carrier injection signal for sideband receive and low level sideband signals in upper and lower sideband transmit.

In the AM transmit mode X201 (6.2565MHz) is selected by S3B. The emitter follower oscillator circuit of Q200 and Q205 provides carrier oscillator output through D208. This signal is mixed with a 20 MHz signal from the synthesizer at Q202, is coupled through T201 to 27MHz amplifier, Q203, and after tuning by T202 exits the board at pin 13.

In the single sideband receive mode a signal (6.2535 in USB, 6.2565 in LSB) is picked directly off Q205 and fed to V502A, the product detector. Here it is mixed with the 6 MHz sideband IF signal resulting in an audio frequency output.

In the sideband transmit mode audio from V601 and V600 is applied via pin 18 to amplifier Q204 and Q206. The resulting audio signal is applied simultaneously with RF from the carrier oscillator/buffer Q200 and Q205, to the input of the ring balanced modulator D211-D214. The output of the ring is double sideband suppressed carrier which is tuned by T200 and fed to the 6 MHz amplifier Q201. C207 and R214 balance the circuit for a null on carrier signals. This signal is then applied to FL200, a steep sided 2.1 KHz crystal filter. The unwanted sideband and any remaining carrier are filtered out at FL200 with the resulting output mixed at the base of Q202 with a 20 MHz signal from the synthesizer. A 27 MHz, upper or lower sideband signal results, (depending on which 6 MHz crystal is selected) and is fed to V700 the RF driver. V701 then amplifies the drive signal at a full 12 watts PEP.

Balanced Modulator Alignment

If low sideband receiver gain, low sideband power out, off frequency operation or poor quality sideband audio is observed, the Balanced Modulator may be in need of alignment.

Balanced Modulator alignments must be performed by those holding First or Second Class F.C.C. Commercial licenses.

If alignment fails to restore proper operation the entire Balanced Modulator Board should be returned to the factory for service.

Carrier Oscillator Calibration (Balanced Modulator Board)

1. Connect a frequency counter to Pin 7 of Balanced Modulator board (See fig. 11)
2. Place D201 in USB mode and adjust C227 for a frequency of 6.2535 MHz.
3. Place D201 in LSB mode and adjust C230 for a frequency of 6.2565 MHz.

Balanced Modulator, Transmit Mixer, 27 MHz Amplifier (Balanced Modulator Board)

1. Remove B+ from V701 (RF Final Amplifier) by disconnecting the orange wire from the junction of R716 and terminal strip.
2. Connect an oscilloscope to V701 Pin 5 (grid of RF Final).
3. Place the D201 in Channel 13, AM transmit.
4. Tune T201 (top and bottom slugs), T202, and T700 for maximum indication. Make note of this indication as reference.
5. Place the D201 in LSB transmit.
6. Connect an audio signal generator to the MIC jack (1500 Hz).
7. Adjust audio generator level and MIC GAIN control for about 1/3 of previous AM transmit indication. Note in the following step it may be necessary to reduce the generator level or MIC GAIN to keep the oscilloscope indication less than the previously noted reference.
8. Tune T200 and T500, and retune T201 (both slugs), T202 and T200 for maximum indication.
9. Remove the audio generator and turn MIC GAIN CCW (minimum).
10. Increase the oscilloscope sensitivity as required and alternately adjust R214 and C207 to suppress the carrier to minimum.

Balanced Modulator Module Replacement

TRAM/DIAMOND CORPORATION has designed the Balanced Modulator module to be easily replaceable. Should the Balanced Modulator module need extensive repair, the technician can simply remove the module and forward it to the factory for replacement or repair.

CAUTION: The Balanced Modulator module contains many delicate electronic components that could be damaged by mishandling. If the module is to be shipped, be sure it is packaged and insured.

Balanced Modulator Return

If it becomes necessary to return the Balanced Modulator to the factory for service, several precautions should be observed:

1. The board must be adequately protected to withstand the rigors of shipping. Packaging should be 2" thick on all sides and firmly hold the board in place.
2. Board should be insured for \$50.00.

3. A detailed note indicating type of failure should accompany board.

Circuit Description – AM Audio Transmit

In the AM mode the D201 transmitter utilizes a four stage audio section and a class C Beam Power Final RF Amplifier with Plate and Screen grid modulation for good linearity.

Low level signals developed at the microphone are fed to V601A, the first microphone pre-amp. amplified signals pass through the mic. gain control, R622B, to V600A, the second mic. pre-amp. Further amplification takes place here with R622A providing Transmitter Tone Control. Audio driver V602A and audio power amplifier V603 raise the level of audio to a value suitable for application to the modulation transformer, T600. Detector Diodes, D604, D605 sample average modulation levels at the primary of T600 and feedback a control voltage to the input of the first microphone pre-amp. controlling gain and modulation levels in the audio section.

AM Audio and Compression Adjust

If problems are encountered in the AM transmit audio, routine signal tracing may reveal failures of the associated audio stages. Proper injection levels are noted on schematic at all feasible injection points for the AM Transmit Mode. Approximately 100% modulation should result from injection at these levels. Most Am Transmit Audio problems will also be manifest as failures of AM receive audio. If problems encountered are particular to AM Transmit, failures of the microphone or compression circuits are indicated. Microphone problems are easily detected by substituting another microphone.

Compression problems may require adjustment of compression. To adjust compression, proceed as follows:

1. Connect an audio generator (1500 Hz) to the MIC jack and 50 ohm load, RF wattmeter and oscilloscope to the antenna jack.
2. Turn R647 and R719 fully CCW. Set MIC GAIN and TTC fully CW.
3. Place the D201 in AM transmit.
4. Increase the generator level and MIC GAIN for 100% modulation, then increase generator level by 10db.
5. Adjust R647 (AM compression) for 95% modulation.
6. Place the D201 in receive.

If compression circuit won't adjust, or adjusts erratically, D604 and D605, as well as associated components should be suspect. (Note: +90 VDC on R647)

Circuit Description – Sideband Audio

Audio signals developed at the microphone are fed through the first and second microphone pre-amp. with Mic. Gain and Tone Control functions accomplished in the same manner as in the AM Mode.

Relatively low level audio is picked off at this point, and fed to pin 18 of the Balanced Modulator Board where balanced modulation, filtering and mixing provide sideband output for the RF driver and Final. Sideband output is sampled through D702 and D703. The resulting voltage is fed back to the first microphone pre-amp through S3C where it is used to control the overall level of transmit power output. A level no higher than 12 watts PEP insures a good quality sideband signal with low intermodulation distortion.

Sideband Audio and ALC Adjustment

If problems are encountered in the sideband transmit mode routine signal tracing may reveal failures of the associated audio stage, the Balanced Modulator or the ALC circuit. Injection levels are noted on the schematic at all feasible points. Signal injection should result in 12 watt PEP sideband output.

Most sideband transmit audio failures will be observed in Sideband Receive also. If problems are particular to the sideband transmit mode, and Balanced Modulator replacement does not cure problem, mal-adjustment or failure of the sideband ALC circuit is indicated.

To adjust sideband ALC, proceed as follows:

1. Connect an audio generator (1500 Hz) to the MIC jack and 50 ohm load, RF wattmeter and oscilloscope to the antenna jack.
2. Turn R719 fully CCW.
3. Place the D201 in LSB transmit.
4. Increase the generator level and MIC GAIN until the power output is 12 watts.
5. Increase the generator level by 10db.
6. Adjust R719 (ALC control) for 12 watts.

If sideband ALC circuit won't adjust, or no output results, D702 and D703 as well as associated components should be suspect. (Note: +90VDC on R719)

RETURNING YOUR D201 FOR FACTORY SERVICE

A D201 owner may return his set to the factory for service at any time. However, unnecessary service returns can often be avoided by a preliminary phone call to our Service Department when problems are of a minor nature.

Ordinary check-ups or routine service is not covered by the warranty. The warranty specifically assures the owner of no unnecessary expense as a result of a unit failure due to component breakdown or poor workmanship within a reasonable time after purchase.

The original shipping carton and its packing materials, if still in good condition, are highly recommended for returning the set for service. If the original carton is not available, the set must be packed carefully, to prevent damage, as follows:

Seal the unit in a close-fitting carton after first wrapping the set in a plastic film to prevent rubbing on the inside of the carton. Pack the carton containing the set in a second carton, allowing space on all six sides for two inches of resilient packing material between the two cartons. The outside carton should be tightly sealed with a suitable sealing tape. The package should also be tied securely with a stout twine to prevent the carton from bursting in handling. In packing, care must be taken to prevent the unit from sliding back and forth inside the cartons.

The package should be marked "FRAGILE" and "DO NOT DROP". A shipping label should be attached indicating to which of our factory service facilities the set is being shipped. Those West of the Mississippi River will realize fastest service from our Tucson plant. When shipping to this facility use the following address:

TRAM DIAMOND CORPORATION
6880 South Tucson Blvd.
Suite 107
Tucson, Arizona 85706

Those East of the Mississippi are advised to use our New Hampshire plant. When shipping to this facility use the following address:

TRAM DIAMOND CORPORATION
Lower Bay Rd.
Winnisquam, New Hampshire 03289

When returning a radio for service, the owner is responsible for all transportation and insurance charges.

Please include a letter with the set, detailing the exact complaint and providing all pertinent information available. Complete information will help the technician working on your set to do the best possible job at the lowest cost.

Specific mention should be made of the following:

1. Modes in which problems occur (eg. Transmit, Receive, AM, USB, LSB, Crystal, Manual, etc.)
2. The channel or channels involved.
3. The effect problem has on S-Meter, if any.
4. Duration of the problem. Eg: constant, intermittent, etc.

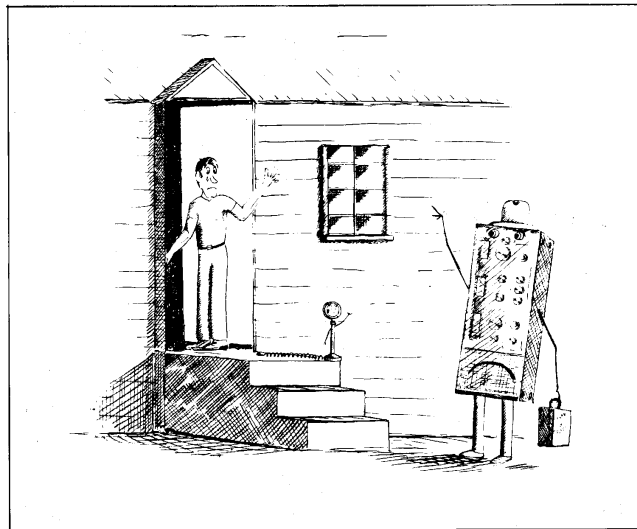

PARTS HOT LINE When ordering parts, please use our PARTS NUMBER, 603-524-3339.

D201 PARTS LIST

SCHEMATIC DESIGNATION	DESCRIPTION	STOCK NUMBER
Power Supply		
	CAPS. (see note)	
C1.	2x .0047	1509800-0
2.	100uf, 25V	1521400-0
3.	100uf, 25V	1521400-0
4.	100uf, 25V	1521400-0
5.	A.B.C. 40uf, 450V	1526900-0
6.	10uf, 450V	1527100-0
7.	.22uf, 400V Mylar	1523600-0
8.	4uf 150V	1524200-0
9.		
10.		
Synthesizer		
C100.	33 Silver Mica (SM)	1513000-0
101.	10	1507300-0
102.	2 - 20 variable	1603300-0
103.	.005	1509000-0
104.	2 - 20 variable	1603300-0
105.	.005	1569000-0
106.	2 - 20 variable	1603300-0
107.	.005	1509000-0
108.	2 - 20 variable	1603300-0
109.	.005	1509000-0
110.	15 SM	1510300-0
111.	33 SM	1513000-0
112.	2pf	1507100-0
113.	.005	1509000-0
114.	.005	1509000-0
115.	.005	1509000-0
116.	.002	1508800-0
117.	33 SM	1513000-0
118.	.002	1508800-0
119.	.005	1509000-0
120.	43 SM	1510600-0
121.	15 SM	1510300-0
122.	.002	1508800-0
123.	15	1507400-0
124.	.002	1508800-0
125.	.002	1508800-0
126.	2 - 20 variable	1603300-0
127.	2 - 20 variable	1603300-0
↓	↓	↓
137.	2 - 20 variable	1603300-0
138.	33pf	1513000-0
↓	↓	↓
149.	33pf	1513000-0
150.	.005	1509000-0
151.	.005	1509000-0
152.	.005	1509000-0

NOTE: When value is 1 or greater, units in picofarads. When value is less than 1, units in microfarads. (unless otherwise noted)

SCHEMATIC DESIGNATION	DESCRIPTION	STOCK NUMBER
153.	.005	1509000-0
154.	.005	1509000-0
155.	160 SM	1511800-0
156.	.005	1509000-0
157.	.005	1509000-0
158.	33	1507700-0
159.	.005	1509000-0
160.	.005	1509000-0
161.	.005	1509000-0

Balanced Modulator

C200.	.005	1509000-0
201.	.005	1509000-0
202.	160 SM	1511800-0
203.	270 SM	1514500-0
204.	10	1507300-0
205.	.002	1508800-0
206.	.002	1508800-0
207.	8-50 Variable	1603400-0
208.	32 SM	1510600-0
209.	.002	1508800-0
210.	1MF 50V	1520100-0
211.	100uf, 25V	1521400-0
212.	.005	1509000-0
213.	33	1507700-0
214.	33	1507700-0
215.	.005	1509000-0
216.	10	1507300-0
217.	22	1507500-0
218.	5	1507200-0
219.	15	1507400-0
220.	.002	1508800-0
221.	.005	1509000-0
222.	15	1507400-0
223.	.002	1508800-0
224.	.002	1508800-0
225.	33	1507700-0
226.	.005	1509000-0
227.	2 - 20	1603300-0
228.	33 SM	1513000-0
229.	.005	1509000-0
230.	2 - 20	1603300-0
231.	33 SM	1513000-0
232.	.005	1509000-0
233.	.005	1509000-0
234.	330	1508300-0
235.	1uf, 50V	1520100-0
236.	1uf, 50V	1520100-0
237.	30uf, 15V	1520800-0
238.	.005	1509000-0
239.	.005	1509000-0
240.	120	1508100-0
241.	82	1508200-0

SCHEMATIC DESIGNATION	DESCRIPTION	STOCK NUMBER
242.	180pf SM	1514200-0
Front End		
C300.	10pf SM	1510100-0
301.	33	1507700-0
302.	.001	1508700-0
303.	.001	1508700-0
304.	.001	1508700-0
305.	15	1507400-0
306.	.001	1508700-0
307.	5	1507200-0
308.	22	1507500-0
309.	.001	1508700-0
310.	.002	1508800-0
311.	5pf	1507200-0
312.	5pf	1507200-0
313.	.01	1509200-0
314.	.005	1509000-0
315.	.001	1508700-0
316.	.001	1508700-0
317.	Tune Cond.	1600100-0
318.	30pf SM	1516200-0
319.	3 - 12 variable	1602200-0
321.	10	1507300-0
322.	430 SM	1515000-0
323.	51 SM	1510800-0
324.	430 SM	1515000-0
325.	.005	1509000-0
326.	15pf SM	1510300-0
327.	51 SM	1510800-0
328.	.005	1509000-0
329.	15pf	1507400-0
330.	.01	1509200-0
331.	.002	1508800-0
332.	.001	1508700-0
333.	.01	1509200-0
334.	.01	1509200-0
335.	.01	1509200-0
336.	.005	1509000-0
337.	.005	1509000-0
AM IF		
C400.	820pf SM	1515400-0
401.	160 SM	1511800-0
402.	.005	1509000-0
403.	.01	1509200-0
404.	.01	1509200-0
405.	.01	1509200-0

SCHEMATIC DESIGNATION	DESCRIPTION	STOCK NUMBER
406.	.01	1509200-0
407.	.01	1509200-0
408.	.01	1522400-0
409.	.01	1509200-0
410.	2pf	1507100-0
411.	.01	1509200-0
412.	50pf	1507900-0
413.	.01	1509200-0
414.	220	1508400-0
415.	15	1507400-0
416.	330	1508300-0
417.	.02	1509400-0
418.	.1uf, 200V Mylar	1522400-0
419.	.02	1509400-0
420.	.01	1509200-0
421.	.005	1509000-0
422.	Deleted	
423.	.01	1509200-0
424.	1uf, 50V	1520100-0
425.	.02	1509400-0
426.	.02	1509400-0
427.	.22uf, 400V	1523600-0
428.	.01	1509200-0
429.	.01	1509200-0
430.	.005	1509000-0
431.	.02	1509400-0
432.	.001	1508700-0
433.	.005	1509000-0
434.	.1uf, 200V	1522400-0
435.	.01	1509200-0
436.	.005	1509000-0
437.	Deleted	
438.	.1	1509400-0
439.	680pf	1508500-0
440.	220pf	1580400-0
441.	510 SM	1515100-0
442.	1500 SM	1516000-0
443.	820 SM	1515400-0
444.	.002	1508800-0
445.	820 SM	1515400-0
446.	1500 SM	1516000-0
447.	510 SM	1515100-0
448.	220 SM	1580400-0
449.	10uf, 450V	1527100-0
Sideband IF		
C500.	33pf	1507700-0
501.	.005	1509000-0
502.	.01	1509200-0
503.	.005	1509000-0
504.	.005	1509000-0
505.	33	1507700-0
506.	.005	1509000-0

SCHEMATIC DESIGNATION	DESCRIPTION	STOCK NUMBER
507.	.01	1509200-0
508.	.005	1509000-0
509.	.01	1509200-0
510.	.005	1509000-0
511.	1uf, 50V	1520100-0
512.	680	1508500-0
513.	.1uf, 200V	1522400-0
514.	.001	1508700-0
515.	.01	1509200-0
516.	Deleted	
517.	.22 400V	1523600-0
518.	4uf, 250V	1527000-0
519.	.01	1509200-0
520.	.01	1509200-0

Audio
C600.

605.	220pf	1508400-0
606.	.005	1509000-0
607.	220	1508400-0
608.	1uf, 50V	1520100-0
609.	680	1508500-0
610.	4uf, 150V	1524200-0
611.	330	1508300-0
612.	.005	1509000-0
613.	.001	1508700-0
614.	220	1508400-0
615.	.01	1509200-0
616.	.005	1509000-0
617.	.01	1509200-0
618.	.001	1508700-0
619.	.1uf, 200V Mylar	1522400-0
620.	330	1508300-0
621.	4uf, 150V	1524200-0
622.	.22uf, 400V	1523600-0
623.	0.02	1509400-0
624.	4X 10uf 500V	1526300-0
625.	4uf, 150V	1524200-0
627.	.005	1509000-0
628.	4uf, 250V	1527000-0
629.	680	1508500-0
630.	.02	1509400-0
631.	.22uf, 400V	1523600-0
632.	.0047uf	1525500-0
633.	330	1508300-0
634.	10uf, 450V	1527100-0
635.	220	1508400-0
636.	Deleted	
637.	"	
638.		

SCHMATIC DESIGNATION	DESCRIPTION	STOCK NUMBER
639.	.22	1523600-0
640.	deleted	
641.	.01	1523600-0
642.	10uf, 15V	1520500-0
Final		
C700.	.001uf, 1KV, (orange drop)	1525200-0
701.	.005	1509000-0
702.	.005	1509000-0
703.	.001	1508700-0
704.	.001	1508700-0
705.	100pf 1KV	1509900-0
706.	35 - 150 variable (30 3M)	1601100-0
707.	15 SM	1510300-0
708.	270 SM	1514500-0
709.	10 SM	1510100-0
710.	.001	1508700-0
711.	3 - 25 Variable Air	1600600-0
712.	100 - 500 variable (304M)	1601300-0
713.	51 SM	1510800-0
714.	5	1507200-0
715.	.01, 500V	1509200-0
716.	680	1508500-0
717.	.01	1509200-0
718.	.001	1508700-0
719.	.001	1508700-0
720.	100pf, 1KV	1509900-0
721.	.001	1508700-0
722.	.001	1508700-0
Blanker		
C800.	10pf	1507300-0
801.	10 SM	1510100-0
802.	.002	1508800-0
803.	.002	1508800-0
804.	.002	1508800-0
805.	22 SM	1510400-0
806.	.002	1508800-0
807.	.01	1509200-0
808.	680	1508500-0
809.	.001	1508700-0
810.	.001	1508700-0
LAMPS		
DS1	#47 bulb	2408100-0
DS2	#47 bulb	2408100-0
DS3	#47 bulb	2407400-0
DS4	#47 bulb	2407400-0
DS700	Mod. light	2407400-0
DS300	SSB light	2407300-0

SCHEMATIC DESIGNATION	DESCRIPTION	STOCK NUMBER
FUSES		
F1	3 MDL 3A slo-blo	5105400-0
F2	AGC1 1A	5105400-0
F3	#28 Bus Wire, 1 inch	6003400-0
F600	1/10A pigtail (3AG)	5105700-0
DIODES		
D1	Pd. 1020	481600-0
2.	↓	↓
3.		
4.		
5.	1N4744	4816000-0
6.	1N4005	4810400-0
7.	1N4005	4810400-0
8.	↓	↓
9.		
10.	1N4005	
11.		
D100.	1N4148	4810700-0
↓	↓	↓
126.	1N4148	4810700-0
127.	MV2115	4815900-0
128.	1N4148	4810700-0
D200.	1N4148	4810700-0
↓	↓	↓
217.	1N4148	4810700-0
D400.	1N4148	4810700-0
401.	1N4148	4810700-0
402.	1N4148	4810700-0
403.	1N4148	4810700-0
D500.	1N4148	4810700-0
501.	1N4148	4810700-0
502.	1N4148	4810700-0
503.	1N4148	4810700-0
504.	1N4148	4810700-0
505.	1N4148	4810700-0
506.	1N4148	4810700-0
507.	1N4148	4810700-0
D604.	1N4148	4810700-0
605.	1N4148	4810700-0
606.	1N4148	4810700-0
607.	1N4005	4810400-0

SCHEMATIC DESIGNATION	DESCRIPTION	STOCK NUMBER
D700.	1N67A	4810200-0
701.	1N67A	4810200-0
702.	1N4148	4810720-0
703.	1N4148	4810720-0
D800.	1N67A	4810200-0
IC800	MC1350-P	3100200-0
	RELAYS	
K600	115 V 9K Allied TF154 6C	4500200-0
	CHOKES	
L100.	1.5 mh	1800900-0
101.		
L200.	1.5 mh	1800900-0
201.	15 uh	1803500-0
L300.	15 uh	1804500-0
301.		
302.	2.2 uh	1804500-0
L400.	Filter	5615200-0
L700.	Air Duct	1820600-0
701.	TVI	1820000-0
702.	1.5 mh	1800900-0
703.	Wrap	6002900-0
704.	15 uh	1803500-0
	METER	
M400	0-1ma	2410700-0
	MICROPHONE	
Mic	Astatic GD104	5505099-0
	TRANSISTORS	
Q1.	2N5295 RCA	4800100-0
Q100.	2N5485	4801500-0
101.	2N3904	4800000-0
102.	2N3904	4800000-0
103.	2N5485	4801500-0
104.	2N3904	4800000-0
105.	2N3904	4800000-0
Q200.	2N3904	4800000-0
201.	2N3904	4800000-0
202.	2N3904	4800000-0
203.	2N3904	4800000-0
204.	2N5485	4801500-0

SCHEMATIC DESIGNATION	DESCRIPTION	STOCK NUMBER
205.	2N3904	4800000-0
206.	2N3904	4800000-0
Q500.	2N3904	4800000-0
501.	2N3904	4800000-0
Q800.	2N3904	4800000-0
801.	2N3904	4800000-0
802.	2N3904	4800000-0

RESISTORS (see note)

Power Supply

R1	4.7 ohm 1/2 watt	4600920-0
2.	2.2K	4107320-0
3.	47 ohm 2 watt	4603380-0
4.	47 ohm 2 watt	4603380-0
5.	47 ohm 2 watt	4603380-0
6.	100 ohm 7 watt wire wound (ww)	4620300-0
7.	220K 1/2 watt	4612120-0
8.	1.5K 7 watt ww	4620700-0
9.	1.5K 7 watt ww	4620700-0
10.	1.5K 7 watt ww	4620700-0

Synthesizer

R100.	100K 1/4w	4611310-0
101.	3.3K	4600700-0
102.	100 ohm	4605710-0
103.	100K	4511300-0
104.	6.8K	4680500-0
105.	470 ohm	4605700-0
106.	470 ohm	4605700-0
107.	22K	4609700-0
108.	10K	4608900-0
109.	10K	4608900-0
110.	1K	4606500-0
111.	2.2K	4607300-0
112.	22 ohm	4602300-0
113.	2.2K	4607300-0
114.	10 ohm	4601700-0
115.	1K	4606500-0
116.	220 ohm	4604900-0
117.	470 ohm	4605700-0
118.	3.3K	4607700-0
119.		
120.		
121.		
121.		
122.		
123.		
124.		
125.		
126.		

NOTE: All resistors 1/4 watt, 10% unless otherwise noted.

SCHEMATIC DESIGNATION	DESCRIPTION	STOCK NUMBER
127.	3.3K	4607700-0
128.	3.3K	4607700-0
129.	3.3K	4607700-0
130.	10K	4608900-0
131.	10K	4608900-0
132.	100 ohm	4604100-0
133.	100 ohm	4604100-0
134.	100 ohm	4604100-0
135.	100 ohm	4604100-0
136.	10K	4608900-0
137.	3.3K	4607700-0
138.	22 ohm	4602500-0
139.	1K	4606500-0
140.	100K	4611300-0
141.	1M	4613700-0
142.	100 ohm	4604100-0
143.	100K Trimpot	4704400-0
144.	10K	4608900-0
145.	2.5K	4703300-0
146.	100K pot	4706300-0
147.	220 ohm	4604900-0
148.	100 ohm	4605700-0
149.	100 ohm	4605700-0
150.	100 ohm	4605700-0

Balanced Modulator

R200.	220 ohm	4604910-0
201.	470 ohm	4605710-0
202.	1.5K	4606910-0
203.	4.7K	4608110-0
204.	2.2K	4607310-0
205.	47 ohm	4603310-0
206.	1.5K	4606910-0
207.	4.7K	4608110-0
208.	1K	4606510-0
209.	1K	4606510-0
210.	1K	4606510-0
211.	1K	4606510-0
212.	100 ohm	4604110-0
213.	100 ohm	4604110-0
214.	1K Trimpot	4700200-0
215.	330 ohm	4605310-0
216.	10 ohm	4601710-0
217.	15K	4609310-0
218.	1K	4606510-0
219.	4.7K	4608110-0
220.	330 ohm	4605310-0
221.	22 ohm	4602510-0
222.	1K	4606510-0
223.	100K	4611310-0
224.	2.2K	4607310-0
225.	330K	4612510-0
226.	15K	4609310-0
227.	470 ohm	4605710-0

SCHEMATIC DESIGNATION	DESCRIPTION	STOCK NUMBER
Balanced Modulator		
R228.	100 ohm	4604110-0
229.	5.6K	4608310-0
230.	330 ohm	4605310-0
231.	4.7K	4608110-0
232.	33 ohm	4602610-0
233.	220 ohm	4604910-0
234.	2.2K	4607310-0
235.	470 ohm	4605710-0
236.	3.3K	4607710-0
237.	470 ohm	4605710-0
238.	3.3K	4607710-0
239.	470 ohm	4605710-0
240.	1K	4606510-0
241.	470 ohm	4605710-0
242.	33K	4610110-0
243.	8.2K	4608710-0
244.	330 ohm	4605310-0
245.	5.6K	4608310-0
246.	5.6K	4608310-0
247.	470 ohm	4605710-0
248.	1K	4606510-0
249.	1K	4606510-0
250.	1K	4606510-0
251.	47 ohm	4603310-0
252.	1K	4606510-0
1/2 watt		
R300.		4606520-0
301.	220 ohm	4604920-0
302.	470K	4612920-0
303.	470K	4612920-0
304.	1K	4606520-0
305.	100K	4611320-0
306.	2.2K	4607320-0
307.	100K 1 watt	4611340-0
308.	100K	4611320-0
309.	1.5K	4606920-0
310.	47K	4610520-0
311.	6.8K	4608500-0
312.	Deleted	
313.	"	
314.	"	
315.	"	
316.	"	
317.	10 ohm	4601720-0
318.	22K	4609720-0
319.	22K 2 watt	4609780-0
320.	22K 2 watt	4609780-0
321.	100K 2 watt	4611300-0
322.	100K 2 watt	4611380-0
323.	2.2K	4607320-0
324.	150K 1/2	4611720-0

SCHEMATIC DESIGNATION	DESCRIPTION	STOCK NUMBER
325.	220K	4612120-0
326.	2.5K RF Gain Pot.	4706400-0
R400.	220K	4612120-0
401.	220 ohm	4604920-0
402.	47K	4610520-0
403.	2.2K	4607320-0
404.	100K	4611320-0
405.	220 ohm	4604920-0
406.	47K	4610520-0
407.	47K	4610520-0
408.	2.2K	4607320-0
409.	10K	4608920-0
410.	1.5K	4606920-0
411.	1 Meg.	4613720-0
412.	68K	4610920-0
413.	150K	4611720-0
414.	1 Meg.	4613720-0
415.	1 Meg.	4613720-0
416.	100K	4611320-0
417.	2.2 Meg.	4614520-0
418.	47K 3 watt metal oxide	4621200-0
419.	47K 3 watt metal oxide	4621200-0
420.	220K	4612120-0
421.	47 ohm	4603320-0
422.	250 Trimpot	4700100-0
423.	220 ohm	4604920-0
424.	220K	4612120-0
425.	1 Meg. Pot	4706600-0
426.	220K 1/2 watt	4612120-0
427.	2.5 Meg. Trimpot	4700500-0
428.	1 Meg.	4613720-0
429.	2.5 Meg. Trimpot	4700500-0
430.	10 Meg.	4616120-0
431.	10 Meg.	4706820-0
432.	1 Meg.	4613720-0
433.	1 Meg.	4613720-0
434.	1 Meg.	4613720-0
435.	10K Pot	4705100-0
436.	220K	4612120-0
437.	100K	4611320-0
438.	220K	4612120-0
439.	2.2K	4607320-0
440.	500K Vol/500K RTC	4706200-0
441.	100K 1 watt	4611340-0
442.	100K	4611320-0
443.	33K	4610120-0
444.	150K	4611720-0
445.	150K	4611720-0
446.	3.3K	4607720-0
R500.	100K	4611320-0
501.	100 ohm	4604120-0
502.	12K 1 watt	4609040-0

SCHEMATIC DESIGNATION	DESCRIPTION	STOCK NUMBER
503.	27K 2 watt	4609920-0
504.	2.2K	4607320-0
505.	100K	4611320-0
506.	100 ohm	4604120-0
507.	12K 1 watt	4609040-0
508.	27K 2 watt	4609980-0
509.	1K	4606520-0
510.	470 ohm	4605720-0
511.	6.8K	4608520-0
512.	100K	4611320-0
513.	220K	4612120-0
514.	220K	4612120-0
515.	220K	4612120-0
516.	1.5K	4606920-0
517.	100K	4611320-0
518.	10K	4608920-0
519.	47K 1 watt	4610540-0
520.	1 Meg.	4613720-0
521.	100K	4611320-0
522.	4.7K	4608120-0
523.	15K	4609320-0
524.	10 ohm	4601720-0
525.	10 ohm	4601720-0
526.	10 ohm	4601720-0
527.	10 ohm	4601720-0
R610.	100K	4611300-0
611.	10K 2 watt	4608900-0
612.	10K 2 watt	4608900-0
613.	10K 2 watt	4608900-0
614.	100K	4611320-0
615.	1 Meg.	4613720-0
616.	47K	4610520-0
617.	1 Meg.	4613720-0
618.	47K	4610520-0
619.	47K	4610520-0
620.	470K	4612920-0
621.	100K	4611320-0
622.	500K/500K MIC/TTC	4706700-0
623.	1K	4606500-0
624.	27K 2 watt	4609980-0
625.	27K	4609980-0
626.	100K	4611720-0
627.	220K	4612120-0
628.	470K	4612920-0
629.	220K	4612120-0
630.	220K	4612120-0
631.	470K	4612920-0
632.	2.2K 1/2 watt	4607320-0
633.	100K	4611320-0
634.	1 Meg.	4613720-0
635.	47K 1 watt	4610540-0
636.	100K	4611320-0
637.	220K	4612120-0
638.	220 ohm 2 watt	4604900-0

SCHEMATIC DESIGNATION	DESCRIPTION	STOCK NUMBER
639.	220 ohm 2 watt	4604900-0
640.	82 ohm 1 watt	4603940-0
641.	10K 2 watt	4608900-0
642.	2.7K 15 watt ww	4620900-0
643.	1.5K 7 watt ww	4620700-0
644.	1 Meg.	4613720-0
645.	47K	4610520-0
646.	330K	4612520-0
647.	100K Trimpot	4706900-0
648.	1K	4606520-0
649.	1K	4606520-0
650.	22 ohm 2 watt	4602580-0
R700	47 ohm 1/4 watt	4603210-0
701.	47 ohm 1/4 watt	4603210-0
702.	68K 1/2 watt	4610920-0
703.	100 ohm 1/2 watt	4601420-0
704.	100 ohm 1/2 w	4604120-0
705.	47K 2 watt	4610580-0
706.	4.7K 7 watt ww	4611200-0
707.	100K Trimpot	4700400-0
708.	100K Trimpot	4700400-0
709.	10K	4608920-0
710.	47K	4610520-0
711.	330 ohm	4605320-0
712.	10 ohm 1/2 w	4601720-0
713.	82 ohm 1 watt	4603940-0
714.	33K 2 watt	4610180-0
715.	33K 2 watt	4610180-0
716.	2.7K 2 watt	4607580-0
717.	10K	4608920-0
718.	47K	4610510-0
719.	100K Trimpot	4706900-0
720.	330K 1/2 w	4612520-0
721.	330K	4612520-0
R800.	100 ohm 1/4 watt	4604110-0
801.	68 ohm	4603710-0
802.	2.5K Trimpot	4700300-0
803.	33K	4610110-0
804.	5.6K	4608310-0
805.	330K	4612510-0
806.	5.6K	4608310-0
807.	1K	4606510-0
808.	10K 1/4 watt	4606510-0
809.	10K 1/4 watt	4606510-0
810.	10K 1/4 watt	4606510-0
	SWITCHES	
S1	AC interlock	5101200-0
2	Part of R622 PWR/OFF	4606700-0
3.	MODE SW	5100300-0
4.	CRYSTAL/MANUAL SW.	5100900-0

SCHEMATIC DESIGNATION	DESCRIPTION	STOCK NUMBER
5.	METER SWITCH	5101000-0
6.	CAL SWITCH	5101300-0
7.	BLANKER SWITCH	5101300-0
INDUCTORS		
T1.	Pwr. Trans.	5615500-0
T100.	RF Transformer, 5/16" dia.	1810700-0
101.	27 MHz Double Tuned, 1/2"	5610700-0
T200.	Bal. Mod. Output, 1/2"	5610800-0
201.	27 MHz Double Tuned, 1/2"	5610700-0
202.	27 MHz Single Tuned, 1/2"	5610400-0
T300.	Receive Antenna Transformer, 3/4"	5610400-0
301.	27 MHz Transformer Double Tuned, 3/4"	5615700-0
302.	6-256 MHz Double Tuned, 3/4"	5615800-0
T400.	455 KHz Double Tuned, 3/4"	5615900-0
401.	455 KHz Double Tuned, 3/4"	5615900-0
T500.	6.256 MHz Single Tuned, 3/4"	5616000-0
501.	6.256 MHz Single Tuned, 3/4"	5616000-0
502.	6.256 MHz Single Tuned, 3/4"	5616000-0
T600.	Mod Trans.	5615600-0
T700.	RF Drive Coil	1810100-0
T800.	25 MHz Single Tuned	5610400-0
801.	25 MHz Single Tuned	5610400-0
Crystal		
X100	Frequency (MHz)	
101	4.400	2304400-0
102	4.410	2304500-0
103	4.420	2305600-0
104	4.440	2304700-0
105	16.3115	2303300-0
106	16.3085	2303200-0
107	16.3615	2303500-0
108	16.3585	2303400-0
109	16.4115	2303700-0
110	16.4085	2303600-0
111	16.4615	2303900-0
112	16.4585	2303800-0
113	16.5115	2304100-0
114	16.5085	2304000-0
115	16.5615	2304300-0
	16.5585	2304200-0
X200	6.2535	2302500-0
201	6.2565	2302700-0
X300	5.8015	2304800-0

SCHEMATIC DESIGNATION	DESCRIPTION	STOCK NUMBER
X400	455KHz resonant filter element	2700300-0
401	455KHz resonant filter element	2700300-0
402	455KHz resonant filter element	2700300-0
403	455KHz resonant filter element	2700300-0
404	455KHz resonant filter	2700400-0
Tubes		
V300	6BQ7A	5700200-0
301	6BK7B	5700400-0
302	6BK7B	5700400-0
V400	6BA6	5700800-0
401	6GH8A	5701400-0
402	12AX7A	4701000-0
V500	6BA6	5700800-0
501	6BA6	5700800-0
502	6GH8A	5701400-0
V600	6GH8A	5701400-0
601	6GH8A	5701400-0
602	6GH8A	5701400-0
603	6L6GC	5701500-0
V700	12BY7A	5701100-0
701	6L6GC	5701500-0
PRINTED CIRCUIT BOARDS		
SA-17017-X	Receiver A Board PCB 'A'	SA-1701799-0
SA-17018-X	Audio 'B' Board PCB 'B'	SA-1701899-0
SA-17015-X	Auxiliary 'A' Board PCB 'AA'	SA-1701599-0
SA-17016-X	Auxiliary 'B' Board PCB 'BA'	SA-1701699-0
SA-17020-X	Balanced Modulator PCB 'D'	SA-1702099-0
SA-17021-X	Synthesizer Board PCB 'C'	SA-1702199-0
SA-17009-X	RF Bridge Board PCB 'E'	SA-1700999-0
PC Board Extender Cards		
	Auxiliary 'A' Board Card	SA-1702299-0
	Auxiliary 'B' Board Card	SA-1702399-0
CABINET PARTS		
	Stabling rails (2)	1403600
	Top cover assembly with trim rail	1403099
	Bottom cover	1401900
	Lower trim rail	1403221
	Wooden cabinet end pieces (2)	1403999
	Rubber foot 9/16"	2800600
KNOBS		
	1-3/4" Knob	2403500
	1-1/8" with mark	2404100
	7/8" with mark	2403600
	7/8" larger of concentric pair	2403799
	1/2" smaller of concentric pair	2403900